



Installation manual

Air heater

Type XR+

CE

Contents

1. Introduction	3	7. Commissioning the air heater	19
1.1. Symbols used in this manual	3	7.1. Adjusting the settings	19
1.2. Warranty	3	7.2. Commissioning the air heater	19
2. Safety instructions	4	8. Combustion settings	21
2.1. Installation	4	8.1. Adjusting the burner settings	21
2.2. Use	4	8.2. Converting to another gas type	21
2.3. Maintenance & Cleaning	4	9. Troubleshooting	22
2.4. Children and vulnerable users	4	9.1. Volatile lock outs	22
3. Technical specifications	5	9.2. Temporary errors	22
3.3. Dimensions	7	9.3. Warnings	22
4. Installation	8	9.4. Instructions	23
4.1. Preparation	8	9.5. Further troubleshooting	24
4.2. Positioning the air heater	8	10. Maintenance	24
4.3. Gas type & connection	10	10.1. Preparation	24
4.4. Electrical connection	10	10.2. Basic maintenance	24
4.5. Room thermostat	10	10.3. Maintenance of the burner unit	25
5. Flue systems	12	11. Electrical wiring diagram	26
5.1. Flue terminals	12	12. Exploded view and spare parts	28
5.2. Flue length (max.)	13	13. Disposal and recycling	29
5.3. Condensate in the flue system	14	14. Declaration of conformity	29
5.4. Installation of the flue terminal	15		
6. Operating the air heater	17		
6.1. Burner cycle	17		
6.2. Minimum firing time	18		
6.3. Delta-T-regulation	18		
6.4. Summer ventilation	18		
6.5. Overheating protection	18		
6.6. Flue passage check	18		

1. Introduction

This manual is intended for the gas, electrical and mechanical installer.

This document gives instructions on how to use and maintain the air heater. It is most important to follow the instructions in this document for safe operation of this air heater.

It is important to read this document before starting the installation process. Store this document close to the air heater for quick reference.

1.1. Symbols used in this manual

DANGER! Indicates a dangerous situation that would lead to death or severe injury.

WARNING! Indicates a potentially dangerous situation that could lead to death, severe injury or serious product damage.

CAUTION! Indicates a potentially dangerous situation that could lead to injury or product damage.

NOTICE Indicates important information that is not directly related to safety.

1.2. Warranty

NOTICE Using, installing or maintaining this air heater in any other way than described in this manual may cause damage that voids the warranty.

NOTICE Failing to follow the safety instructions in this manual can lead to damage to the air heater or the installation and void the warranty.

2. Safety instructions

Always follow the safety instructions in this chapter when installing, using or performing maintenance on this air heater:

2.1. Installation

CAUTION! This air heater must be installed and maintained by an authorized, qualified and competent installer, using calibrated equipment.

NOTICE This air heater must be installed and maintained in accordance with this manual, national and local building regulations and local health and safety regulations.

2.1.1. Protection against dust

CAUTION! Do not use the air heater in a very dusty environment. Dust may accumulate and cause a defect of the heater. This is also the case for the room thermostat.

2.1.2. Temperature

CAUTION! Do not install the heater in places where the temperature can rise above 35°C. Higher temperatures cause the internal components to degrade much faster.

NOTICE Air heaters installed in very cold environments may form condensate in the flue system. Make sure a condensate discharge is installed.

2.1.3. Corrosive vapours

WARNING! Do not install the air heater in areas that contain any corrosive or explosive vapours. Corrosive vapours (e.g. containing Chlorine) that are sucked into the air intake will cause corrosion of the heat exchanger and a leakage of condensate and flue gas. This is also the case for the room thermostat.

2.1.4. Protection against water

WARNING! Never use water when cleaning electrical parts.

This air heater is not waterproof and has an IP00B classification.

WARNING! Do not expose the air heater to rain, spray or dripping water.

2.2. Use

CAUTION! Make sure the area around the air heater is dry when performing maintenance on the air heater.

CAUTION! Always close the doors and inspection hatches of the air heater, except when adjusting and checking the appliance.

2.3. Maintenance & Cleaning

Frequent maintenance and cleaning of the air heater is necessary to ensure safe and proper operation. Failure to do so could lead to damage to the heater or its surroundings and void the warranty.

2.3.1. Protection from water (IP class)

WARNING! Never use water when cleaning electrical parts.

This air heater is not waterproof and has an IP00B classification.

WARNING! Do not expose the air heater to rain, spray or dripping water.

2.4. Children and vulnerable users

WARNING! This air heater can be used by children aged 8 years and above and by persons with reduced physical, sensory or mental capabilities or lack of experience and knowledge, if they are supervised or instructed concerning use of the appliance in a safe way and understand the hazards involved.

WARNING! Children shall not play with the air heater.

WARNING! Children shall not clean and maintain this air heater without supervision.

3. Technical specifications

3.1. Performance

Type XR+ 5.1 (ERP2021)

Technical specification	Unit	XR10+	XR20+	XR30+	XR40+	XR50+	XR60+	XR80+	XR100+
Net nominal heat input (max.)	kW	14.0	22.8	32.0	44.0	55.0	66.0	80.0	100.0
Net nominal heat input (min.)	kW	8.5	13.5	18.0	26.4	33.0	39.6	60	72
Heat output (max.)	kW	12.5	20.7	28.9	41.1	50.7	61.2	75.7	96.0
Heat output (min.)	kW	8.0	12.8	17.0	25.3	31.5	37.9	57.6	69.5
Efficiency at max. power	%	90.4	90.6	90.4	93.5	92.2	92.7	94.6	96.0
Efficiency at min. power	%	93.8	94.6	94.6	95.8	95.6	95.6	96.0	96.5
Air output (max.)	m ³ /h	2950	4000	4200	6000	8500	8500	12000	14400
Throw horizontal (max.)	m	22	30	31	32	46	30	52	53
Throw vertical (max. warm)	m	5	7	7	8	11	8	-	-
Gas connection	G"	1/2"	1/2"	1/2"	3/4"	3/4"	3/4"	1"	1"
Electrical connection (50 Hz)	V	230	230	230	230	230	230	230	230
Electrical power consumption (max.)	kW	0.200	0.300	0.300	0.325	0.750	0.750	0.700	1.000
Electrical power consumption (min.)	kW	0.165	0.270	0.270	0.250	0.600	0.600	0.345	0.750
Stand-by electrical power consumption	kW	0.004	0.004	0.004	0.004	0.004	0.004	0.006	0.006
Electrical current (max.)	A	0.9	1.4	1.4	1.5	3.5	3.5	3.3	4.5
Protection class	-	IP00B							
Emission efficiency (η_s , flow)	%	96.8	96.3	95.1	94.2	94.9	94.0	96.1	96.8
Seasonal space heating efficiency	%	78.3	78.1	78.4	78.3	78.8	78.3	78.8	78.9
NOx emission (GCV)	mg/kWh	48	48	45	39	49	45	43	62
NOx class	-	5	5	5	5	5	5	5	5
Flue gas amount (max.)	kg/h	21.7	35.5	51.3	70.6	88.2	105.8	128.4	160.3
Thermostat communication bus system (low voltage)	-	2-wire low voltage communication bus							
Chimney flue pressure (max.)	Pa	90	90	90	120	120	120	130	130
Sound level high (at 5 m)	dBA	56.5	58	59	59	64	64	62	62
Sound level low (at 5 m)	dBA	54	56.5	56	54.5	58	58	58	58
Min. suspension height (horizontal throw)	m	2.7	2.7	2.7	2.7	2.7	2.7	2.7	2.7
Min. suspension height (vertical throw)	m	4	4	4	5	6	6	-	-
Flue length horizontal throw	See §5.2								
Flue length vertical throw									
Weight	kg	46	50	53	78	86	82	185	205

3.2. Gas types

3.2.1. Natural gas G20

Specification	Unit	Natural gas G20							
Nominal supply pressure	mbar	20							
Supply pressure (min. - max.)	mbar	17-25							
Gas category	-	I ₂ H							
Class	-	B23, C13, C33							
Specification	Unit	XR10+	XR20+	XR30+	XR40+	XR50+	XR60+	XR80+	XR100+
Gas consumption (max.)	m ³ /h	1.5	2.4	3.4	4.7	5.8	7.0	8.5	10.6
CO ₂ High	%	9.1	9.0	9.0	9.0	9.0	9.0	9.0	9.1
CO ₂ Low	%	8.5	8.5	8.5	8.5	8.6	8.6	8.5	8.7
O ₂ High	%	4.7	4.8	4.8	4.8	4.8	4.8	4.7	4.7
O ₂ Low	%	5.8	5.8	5.8	5.8	5.6	5.6	5.7	5.4

3.2.2. Propane G31

Specification	Unit	Propane							
Nominal supply pressure	mbar	30-50							
Supply pressure (min. - max.)	mbar	25-50							
Gas category	-	I ₃ P							
Class	-	B23, C13, C33							
Specification	Unit	XR10+	XR20+	XR30+	XR40+	XR50+	XR60+	XR80+	XR100+
Gas consumption (max.)	kg/h	1.1	1.8	2.5	3.5	4.4	5.3	6.4	8.0
CO ₂ High	%	11.0	10.8	10.8	10.8	10.8	10.6	10.9	11.0
CO ₂ Low	%	10.5	10.5	10.5	10.5	10.3	10.3	10.5	10.5
O ₂ High	%	4.2	4.5	4.5	4.5	4.5	4.8	4.3	4.2
O ₂ Low	%	5.0	5.0	5.0	5.0	5.3	5.3	5.0	5.0

3.3. Dimensions

The dimensions of this air heater can be found in figures 1 through 3.

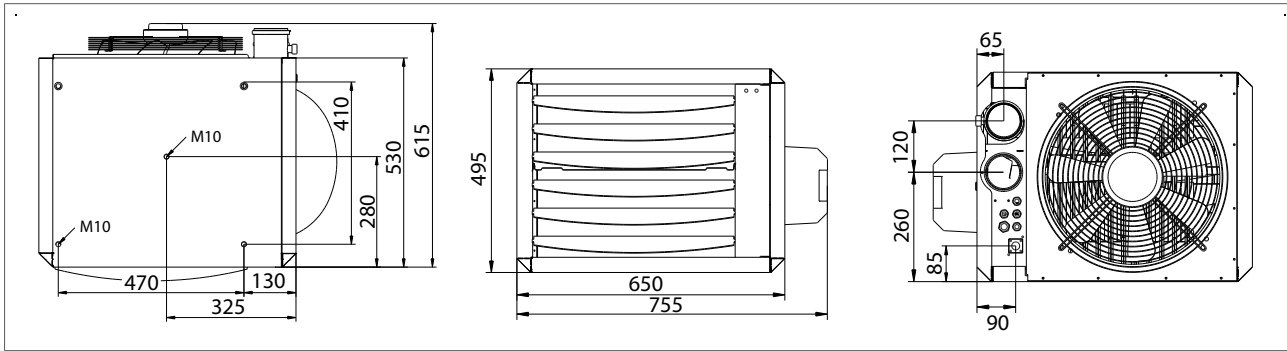

Figure 1 - Dimensions of the XR10+ - XR30+

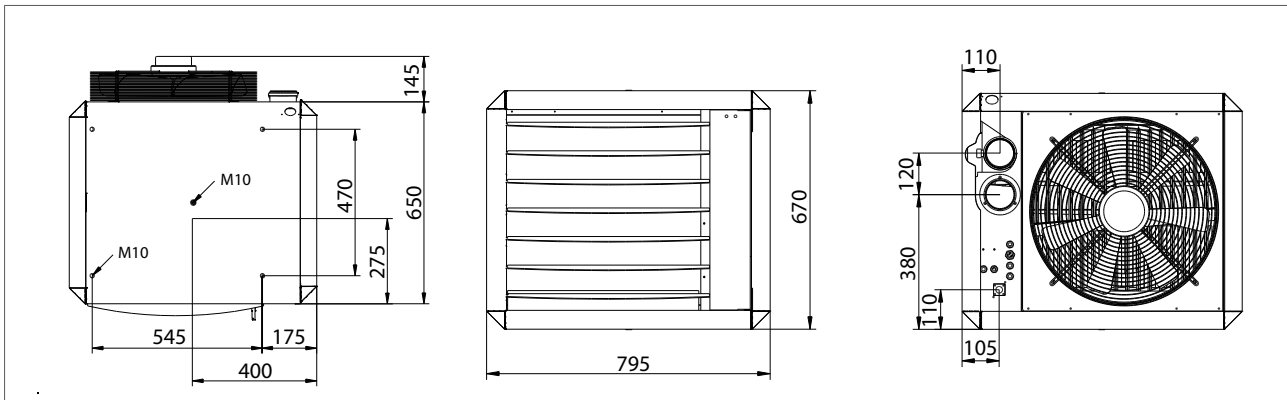

Figure 2 - Dimensions of the XR40+ - XR60+

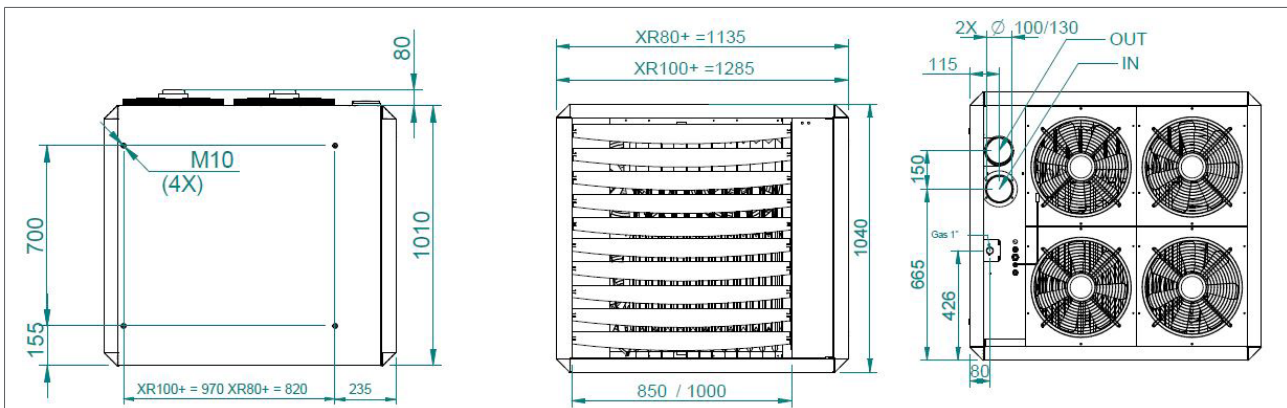

Figure 3 - Dimensions of the XR80+ - XR100+

4. Installation

4.1. Preparation

Before installation, please use the data badge to check:

- if the heater is in accordance with the order;
- if the heater is suitable for the local present provisions (gas type, gas pressure, electrical supply etc.)

Before leaving the factory, the air heater has been tested for safety and has been set to the operating settings. It has been configured for the type of gas that is stated on the data badge. Should there be any doubt about the settings that apply to your situation, please contact your supplier.

4.1.1. Standards

NOTICE The installation must comply with all applicable local and national standards.

NOTICE The air heater must be installed in accordance with the relevant requirements of the Gas Safety regulations, Electrical installation regulations and or other local regulations that may apply.

For United Kingdom only:

NOTICE The air heater must be installed in accordance with the relevant requirements of the Gas Safety regulations, Electrical installation regulations and or other local regulations that may apply (e.g. The Institute of Gas Engineers IGE UP-1 and 2, BS6230, BS5440 building regulations and the IIE regulations that incorporate the gas safety regulations).

4.2. Positioning the air heater

Keep the following requirements in mind when choosing a location to install your air heater:

WARNING! Never install an air heater close to flammable materials.

- Keep sufficient distance between the heater and any obstructions. This is both for safety reasons and to allow access for service and maintenance (figure 4).
- Make sure the air flow to and from the heater is free from obstacles at least 5 metres in front of the heater. Also make sure the air intake is free from obstacles.

- Make sure enough space remains to open the door of the air heater.
- Make sure the wall can support the air heater.
- Ensure sufficient clearance distance for the flue system.

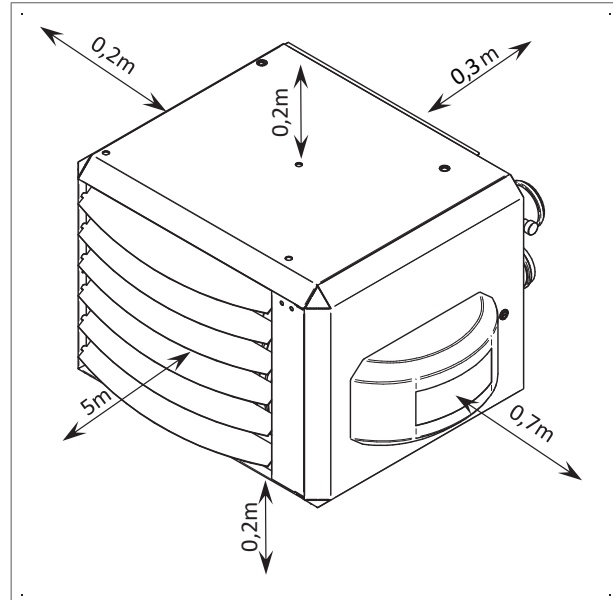

Figure 4 - Minimum clearances around the air heater

4.2.1. Orientation

- When the heater is not installed horizontally, re-adjust the CO₂ setting from the gas valve.
- If the air heater is installed with the air stream vertically downwards, maintain a maximum suspension height of 8 meters to ensure that warm air will reach the floor.

4.2.2. Suspension

Depending on the model of your air heater, five types of wall support can be used:

Model(s)	Wall support	Art. Nr.
XR10+ - XR30+	Standard	GA8610
XR40+ - XR60+	Standard	GA8620
XR80+ - XR100+	Standard	GA8622
XR10+ - XR30+	Turnable*	GA8630

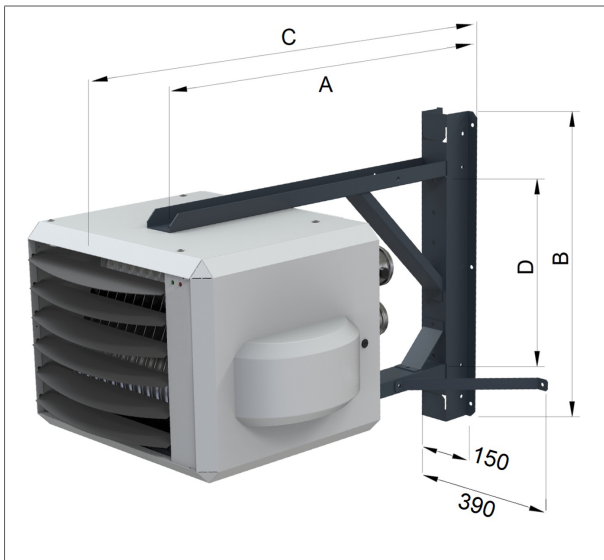

Figure 5 - Wall support (standard)

Dimension	XR10+ - XR30+	XR40+ - XR60+
A (mm)	550	665
B (mm)	640	815
C (mm)	830	990
D (mm)	540	720

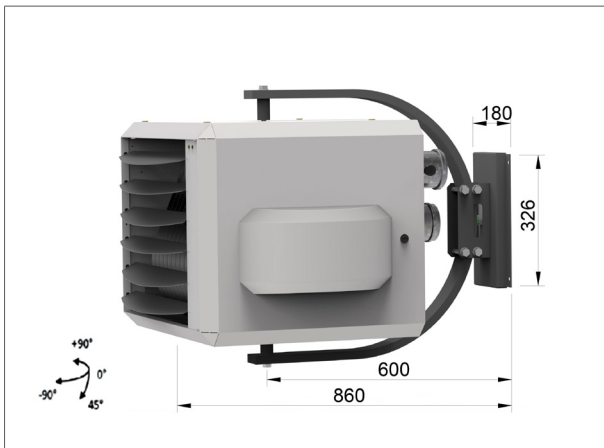

Figure 6 - Wall support (turnable)

*can be rotated horizontally or forward.

Model(s)	Wall support	Art. Nr.
XR10+ - XR60+	Vertical suspension kit	GA8645

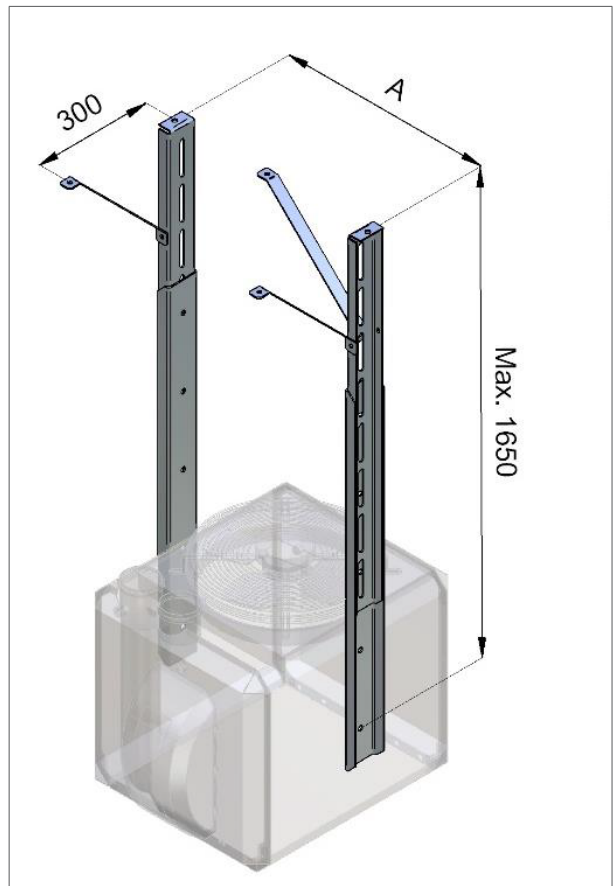

Figure 7 - Vertical suspension kit

Dimension	XR10+ - XR30+	XR40+ - XR60+
A (mm)	540	720



Figure 8 - Suspension adapter GA8622

The air heater is equipped with threaded sockets to suspend the unit (see §12.).

- Use the suspension kit that is compatible with your air heater. The suspension kit is not delivered with the air heater. Contact your supplier.

4.3. Gas type & connection

The unit is suited for the use of natural gas or propane gas.

The specific gas type that a heater is set up for can be found on the packaging labels and on the heater badge. The heater can be converted to another gas type. Contact your supplier for more information.

The working and standing supply pressure must be a minimum of 17 mbar, and a maximum of 50 mbar, measured at the inlet pressure nipple of the gas control in the heater.

NOTICE The supply line's manual isolation valve must be placed within reach of the heater.

NOTICE All gas supply lines must be mounted without any mechanical tension.

NOTICE Always clean the inside of a gas supply line before connecting it to the air heater. Place a gas filter in the supply line when needed.

CAUTION! When using pressures above 60 mbar to test the supply lines, always close the manual isolation valve of the air heater.

For United Kingdom only:

The supply line for gas must comply with the Gas Engineers publications UP-1 and UP-2, as well as with BS 6891.

4.4. Electrical connection

The electrical installation must comply with local and national requirements as well as IEE regulations.

4.4.1. Power supply

The air heater requires an earthed power supply of 230 V/AC. The control circuit is a two wire low voltage bus communication.

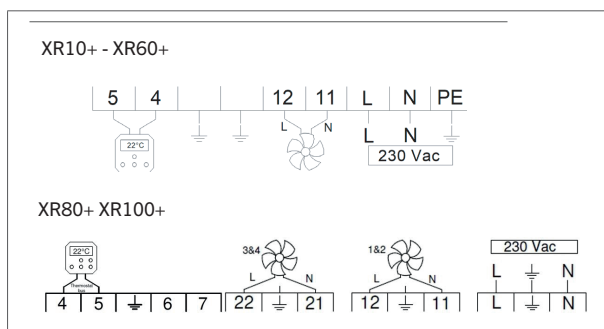

Figure 9 - The air heater's connection clamps

- Connect the wires of the mains cable to the clamps in the connection box (figure 9).
- The heater must be electrically isolated during servicing. Use an isolation switch (min. 3 mm contact opening gap), a power plug or a non-switched fuse spur. See the electrical wiring diagram in §11..

WARNING! Never use a room thermostat to interrupt the electric power supply to the heater.

4.4.2. Fuse

One fuse is present on the air heater's control board (see the electrical wiring diagram in §11.).

- When replacing this fuse, always use one of the same type (5AT).

4.5. Room thermostat

The heater can only be controlled with one of the following Winterwarm modulating room thermostats:

- **The MTS:** a modulating digital thermostat.
- **The MTC:** a modulating digital clock thermostat with optimiser.
- **Interface module;** a specially designed interface module for BMS systems. Contact your supplier for more information.

WARNING! Never use a room thermostat to interrupt the electric power supply to the heater.

NOTICE This air heater must not be controlled with a simple ON/OFF thermostat due to ERP requirements.

4.5.1. Installation requirements

Following these requirements when placing the thermostat to ensure the heater functions correctly:

- Make sure that air can circulate around the thermostat.
- Make sure the sun does not shine directly upon the thermostat.
- Do not place the thermostat on a cold wall.
- Place the thermostat on an inner wall free from draught.
- Never place the thermostat within the throw of the heater.
- Never mount the thermostat near the aerials of internal communication networks. These emit radiation that can disturb the thermostat. Keep several meters distance.

In all cases, the communication between the heater and the thermostat is based on a two wire, low-voltage connection. (see the electrical wiring diagram in §11.). Follow these instructions to prevent malfunction of the installation and damage to the thermostat or air heater:

- Use a cable with the following specifications:
 - Signal cable.
 - Shielded and twisted.
 - Minimum dimensions: 1 x 2 x Ø0,8 mm².
 - Maximum length: 200 m.

CAUTION! Keep the thermostat cable separated from the mains cables.

CAUTION! Connect the cable's earth shield only to the earth terminal inside the air heater. Do not connect the other end of the cable's earth shield.

NOTICE A cable with a thickness of less than 0.8 mm will result in a poor signal.

NOTICE A cable that is not shielded and twisted may result in a disturbed communication in an EMC-unfriendly environment.

4.5.2. Modulating room thermostat installation

To connect the air heater to an MTS or MTC thermostat, do the following:

1. Connect the two control wires to terminals 4 and 5 (see figure 10 or the electrical wiring diagram in §11.).
2. Set the S1 and J14 switches on the control unit as follows (figure 11 / 12):
 - a. Set S1 to 1.
 - b. Set J14 to 1.

NOTICE The air heater must be switched off when setting the switches. Otherwise the settings will have no effect.

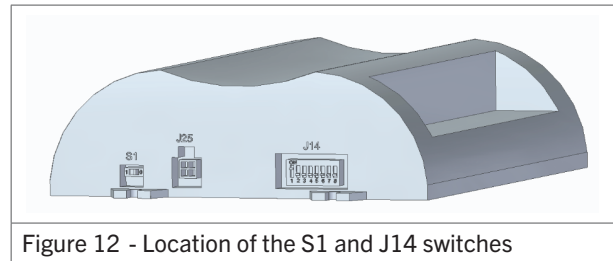
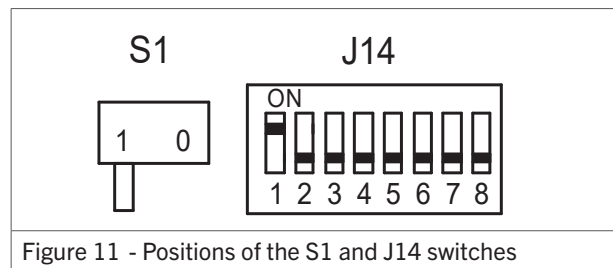
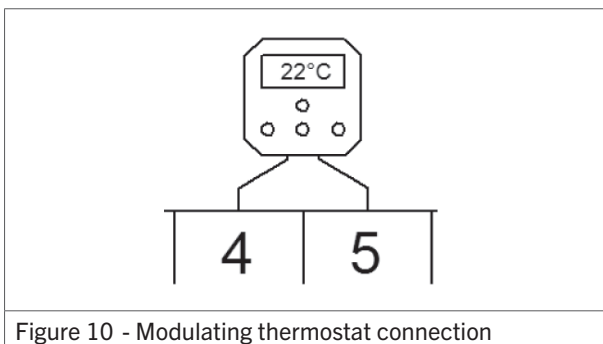

4.5.3. Installation of multiple heaters on one control unit

An MTC or MTS room thermostat, or interface module can control up to 8 air heaters. To connect the air heaters, do the following (figure 13):

1. Connect the two wires of the thermostat to terminals 4 and 5 of the first air heater.
2. Connect the first air heater to the second air heater.
3. Repeat for each subsequent air heater.

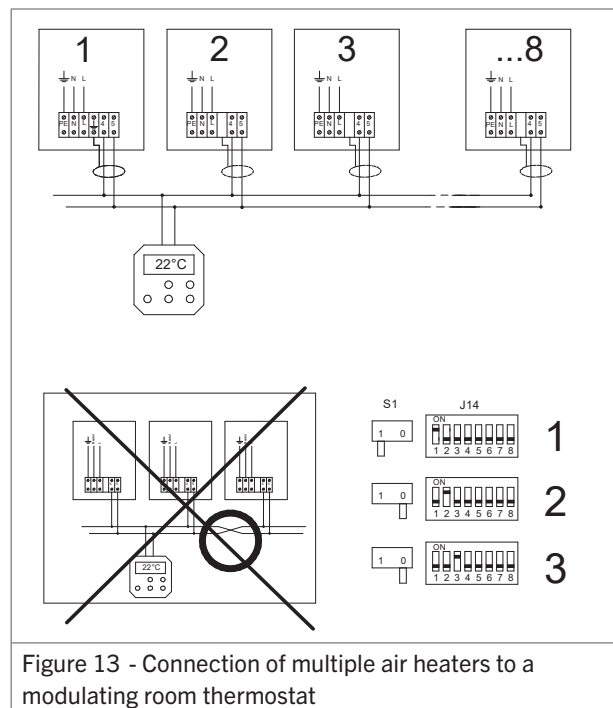

Each air heater needs an unique number to be recognised by the room thermostat. This number can be set with the J14 switch on the control unit of each air heater:

1. Set the S1 and J14 switches on the control unit as follows (figure 14):
 - a. Set the S1 switch of the first air heater to 1.
 - b. Set the S1 switch of the other air heaters to 0.
 - c. Set the J14 switch of the first air heater to 1.
 - d. Set the J14 switch of the second air heater to 2, etc.

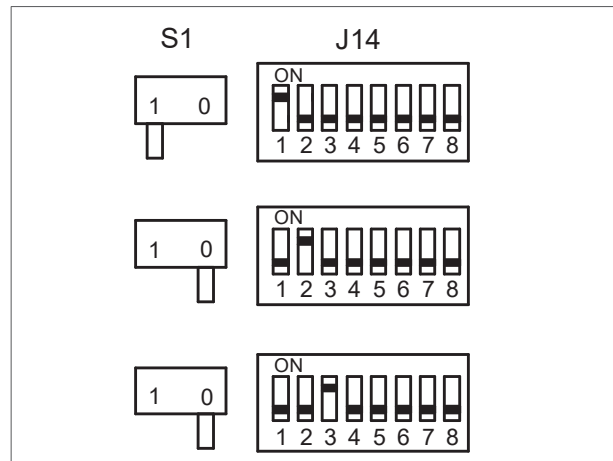

Figure 14 - Positions of the S1 and J14 switches for the first three air heaters in a system

NOTICE If the J14 switch of more than one air heater is set to the same number, the system will not work.

NOTICE The air heater must be switched off when setting the switches. Otherwise the settings will have no effect.

5. Flue systems

To ensure safe and proper use, this air heater must be connected to a flue system. This flue system must be installed according to this manual as well as national and local regulations. A flue system consists of a flue terminal, piping and an optional condensate discharge system.

CAUTION! Do not use flue terminals for condensing appliances on non-condensing heaters. This can lead to water inside the flue system.

NOTICE Only use the prescribed flue material for the roof terminal, wall terminal and for the piping between the heater and the terminal. This is the only way the installation will be approved.

NOTICE Local regulations can require the flue terminal to be placed at least 0,6 m above roof level.

NOTICE Local regulations can require a minimum distance between the flue terminal and air ventilation openings on the building.

5.1. Flue terminals

The following flue terminals are compatible with this air heater:

Model(s)	Vertical discharge	
	Flue terminal	Art. Nr.
XR10+ - XR60+	DDV 80/125	IA8202*
XR80+	DDV100/150	IA8101
XR100+	DDV130/200	IA8305

* For $h > 0,5\text{m}$ above the roof, use art.nr. IA8218

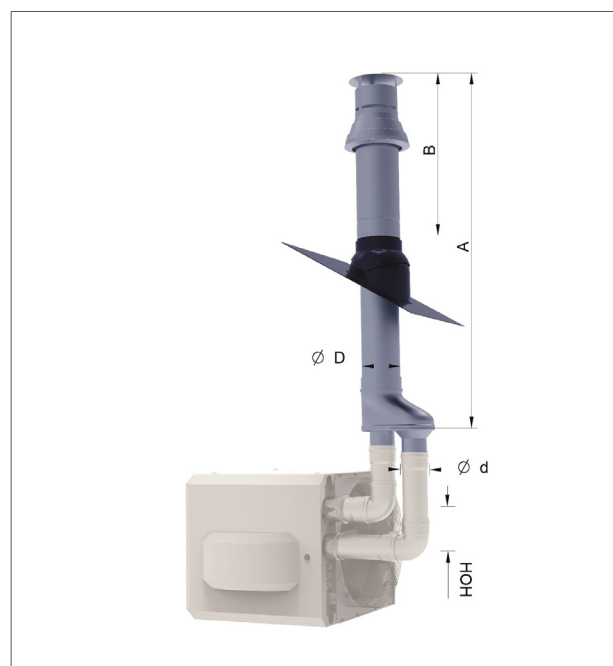

Figure 15 - Vertical flue terminal XR+

Dimension	XR10+ - XR30+	XR40+ - XR60+	XR80+	XR100+
A (mm)	1200	1200	1200	1850
B (mm)	400	400	500	955
d (Ø mm)	80	80	100	130
D (Ø mm)	125	125	150	200
HOH (mm)	110	110	140	225

Model(s)	Horizontal discharge	
	Flue terminal	Art. Nr.
XR10+ - XR60+	CT 80/125	IA8113
XR80+	CT100/150	IA8112
XR100+	CT130/200	IA8312
XR10+ - XR30+	2-pipe terminal	GA8201

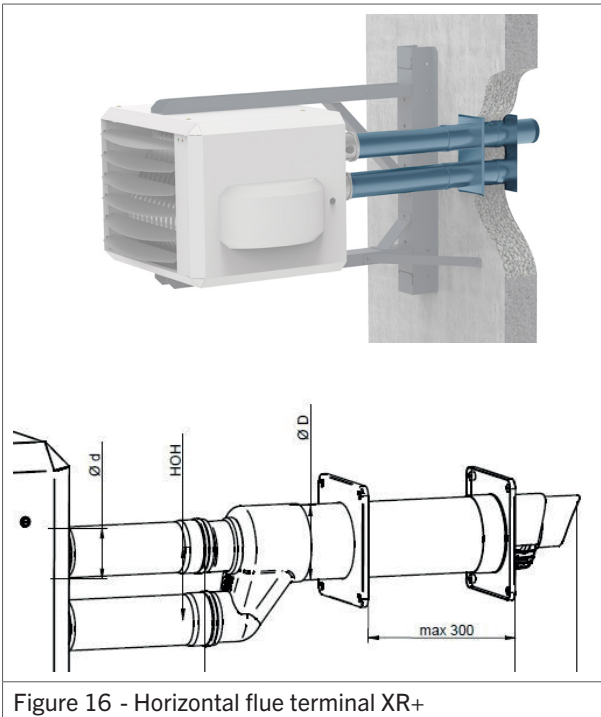

Figure 16 - Horizontal flue terminal XR+

Dimension	XR10+ - XR30+	XR40+ - XR60+
d (Ø mm)	80	100
D (Ø mm)	125	150

5.1.1. Flue material

Only use CE marked flue material from the manufacturers Muelink & Grol (M&G) and Burgerhout.

Use type Alu-fix with a minimum temperature class of T250 P1.

Use flue pipes with the same diameter as the flue spigots on the heater.

Contact your supplier to purchase these flue materials.

NOTICE Different manufacturers use different connections systems for flue pipes. Do not combine systems from different manufacturers.

5.2. Flue length (max.)

The maximum straight length L (m) between the air heater and its flue terminal for both orientations is:

Heater orientation	Horizontal	Horizontal	Vertical
Flue outlet	Horizontal (wall)	Vertical (roof)	Vertical (roof)
Figure	Figure 17	Figure 18	Figure 19
XR10+ - XR30+	6	6	2
XR40+ - XR60+	8	8	2
XR80+ - XR100+	9	9	-

Bends that are used in the connection between an air heater and the flue terminal cause a decrease in pressure:

- Using a 90° bend decreases the maximum length of the connection by 2 meters.
- Using a 45° bend decreases the maximum length of the connection by 1 meter.

For further information regarding the flue system, please contact your supplier.

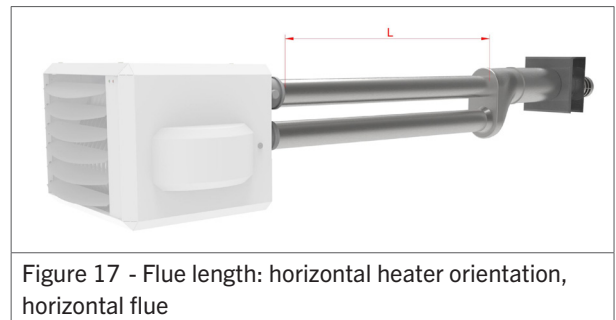

Figure 17 - Flue length: horizontal heater orientation, horizontal flue



Figure 18 - Flue length: horizontal heater orientation, vertical flue

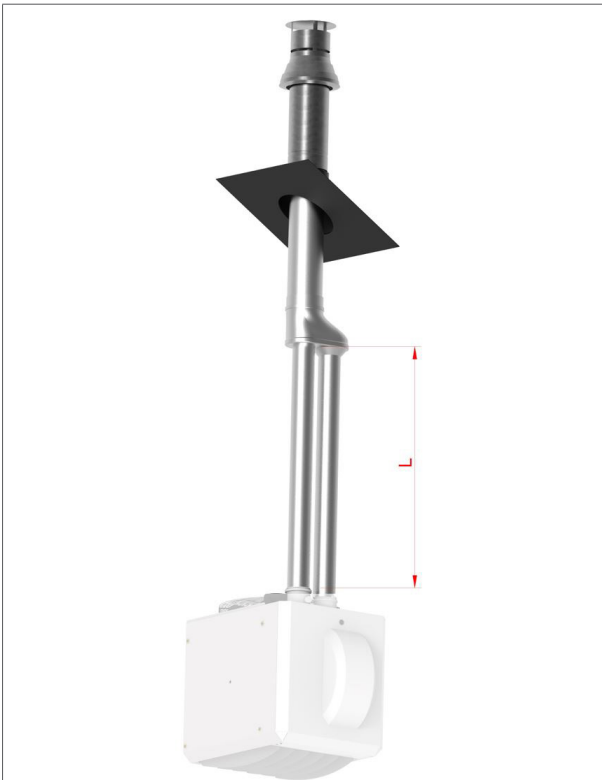

Figure 19 - Flue length: vertical heater orientation, vertical flue

5.3. Condensate in the flue system

Condensate can form in the flue system when the air heater is heating up. This condensate will evaporate if the heater is operating for a longer period of time. The forming of condensate depends on the following factors:

5.3.1. Air heater type

Condensate is especially likely to form in the smaller heaters (< 25 kW).

Condensate will most likely not form in the larger heaters (> 25 kW).

5.3.2. Air heater location

When an air heater burns frequently and is placed in a normally heated room (temperature above 15 °C), condensate is unlikely to form.

Air heaters placed in a room that needs to be heated to just above 5 degrees will only burn for short periods at the time. Formed condensate will not evaporate in these short burning periods. The condensate will accumulate and eventually result in pressure switch errors. To prevent this:

- Add a T-piece (figure 20).
- or
- Add a condensate drain (figure 21).

5.3.3. Flue pipe length

When the flue pipe is long and runs through a cold space, condensate can form. If the straight length of the flue pipe is longer than 4 meters, the condensate will not evaporate and accumulate in the heater. In this case. To prevent this:

- Insulate the flue pipes.
- or
- Place a condensate trap (figure 20).

	T-piece (6)	Condensate trap (7)	Condensate drain
Ø80 art.	IA8223	IA8225	IA8286

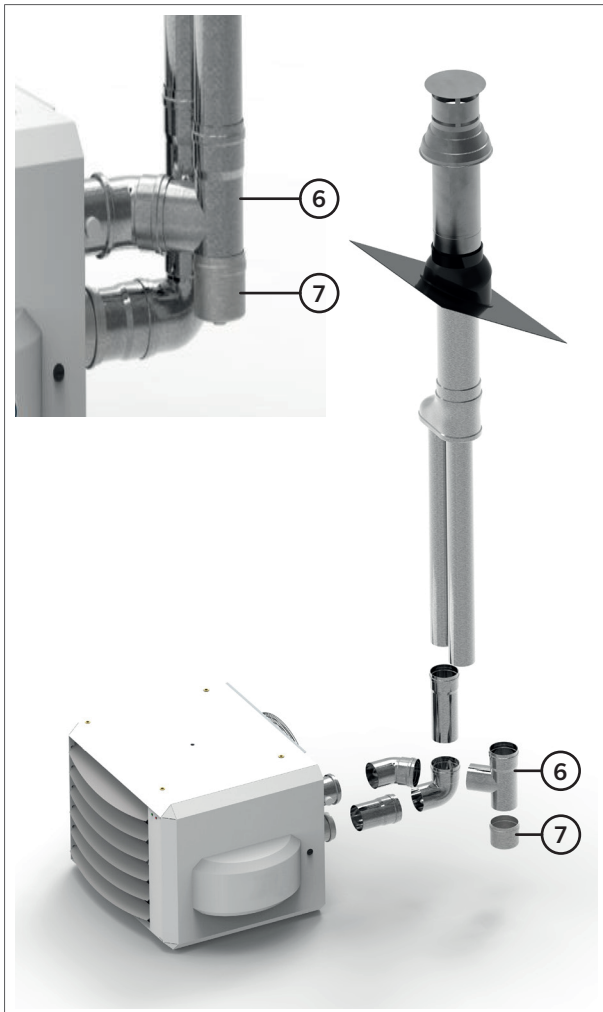

Figure 20 - A T-piece (6) and condensate trap (7)

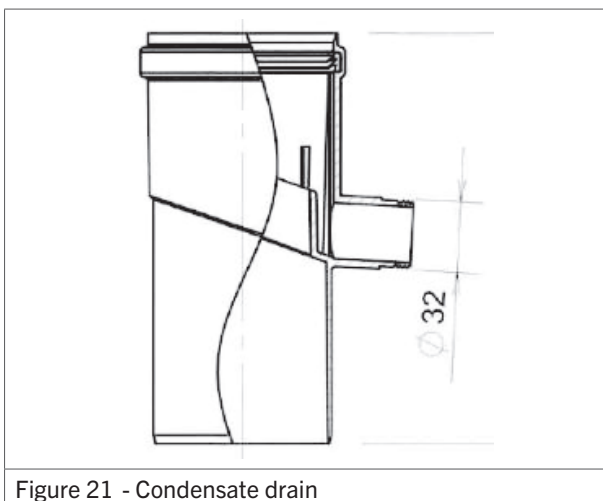

Figure 21 - Condensate drain

5.4. Installation of the flue terminal

There are flue terminals available for installation through a roof or through a wall.

NOTICE The flue terminal must be installed according to local and national regulations.



NOTICE Do not combine components or materials from different manufacturers.

5.4.1. Installation - Roof terminal

To install the flue terminal in the roof, do the following:

5.4.1.1. Preparation

1. Check all components for possible damage.
2. Determine the roofing type:

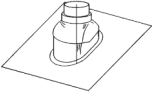
				
Flat roof flashing	Synthetic tile	Universal pitched roof flashing.		
Ø80 - 130	IA8121	Ø130 - 210	GA8334	

3. Determine where the flue terminal will be positioned.

5.4.1.2. Installation

1. Create a hole from the outside of the roof.

CAUTION! Make sure no debris or dust gets into the air heater.

2. Install the weather collar.
3. Carefully insert the flue terminal from the outside.

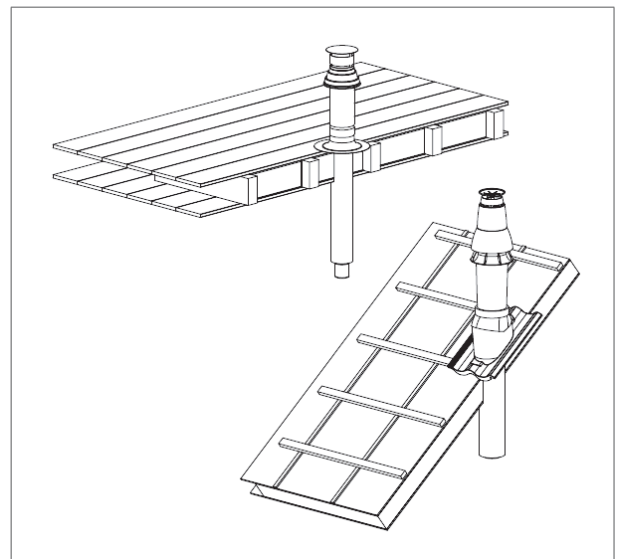

CAUTION! Do not rotate the cap.

4. Put the flue terminal into a vertical position. Use a level.
5. OPTIONAL - If desired, fit cover plates. These are supplied separately.
6. Place the supplied wall clamp around the flue terminal and fit it to the roof construction. Do not tighten the clamp yet.
7. Connect the gasket and the twin-tube connection. Make sure that the gasket is not damaged.

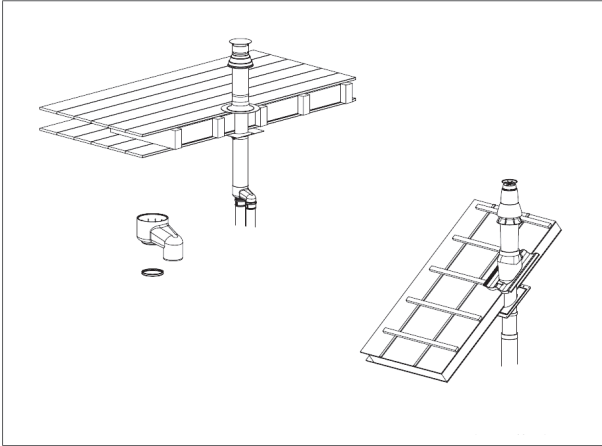

NOTICE Make sure the flue tube and the air inlet tube are not mixed up. The flue tube should be in the centre of the flue terminal.

8. Tighten the roof wall clamp.
9. Check if all steps have been carried out correctly.

5.4.2. Installation - Wall terminal

To install the flue terminal in a wall, do the following:

5.4.2.1. Preparation

1. Check all components for possible damage.
2. Determine where the flue terminal will be positioned.

5.4.2.2. Installation

1. Create a hole through the wall.

CAUTION! Make sure no debris or dust gets into the air heater.

2. Carefully insert the flue terminal from the outside.

CAUTION! Do not rotate the cap.

3. Put the flue terminal in a horizontal position. Use a level.
4. Mark the holes on the wall.
5. Drill the holes.
6. Insert screws to fix the terminal in place.
7. Seal the edges of the flue terminal with kit.
8. Fix the shield on the inside of the wall.

CAUTION! Make sure that the gasket is not damaged.

9. Connect the gasket and the twin-tube connection.

NOTICE Make sure the flue tube and the air inlet tube are not mixed up. The flue tube should be in the centre of the flue terminal.

10. Check if all steps have been carried out correctly.

5.4.3. Installation of the flue system parts

This chapter gives the instructions for installing an ALU FIX flue system.

5.4.3.1. Requirements

The installation must follow these requirements:

- Minimum distance between the flue system and combustible materials of 40 mm.
- Minimum depth of female sockets of 40 mm.
- Minimum slope of horizontal piping of 50 mm/m (3°). This allows condensate to flow to the heater.

NOTICE Use brackets that match the flue system. Different manufacturers use different connection systems for flue pipes. It is not allowed to combine systems from different manufacturers.

5.4.3.2. Elements system ALU FIX thick wall

An ALU FIX flue system is created with four elements (figure 22).

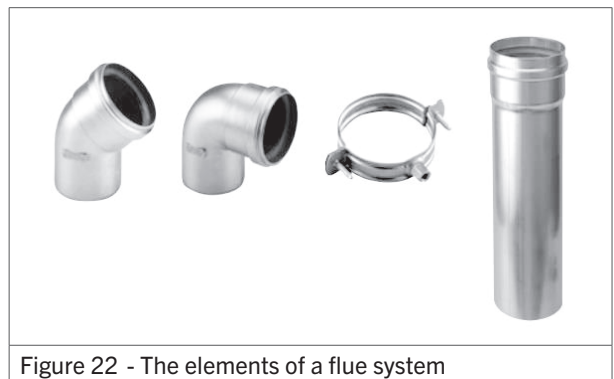

Figure 22 - The elements of a flue system

5.4.3.3. Seals

The connection between the different flue elements must be made airtight and waterproof with silicon seals.

CAUTION! If the flue elements have been cut, make sure to clean and chamfer the edges. Sharp edges will damage the seals.

CAUTION! Do not drill or screw in the flue elements.

CAUTION! Do not try to seal the connections with kit, foam or tape.

CAUTION! Do not use grease, vaseline or oil to lubricate the installation.

CAUTION! Only use the lubricant allowed by the manufacturer to lubricate the connections. A maximum soap concentration of 1% is allowed.

NOTICE Follow the instructions from the manufacturer if the connections need to be fixed.

5.4.3.4. Installation

Take note of the following rules and requirements when installing a flue system:

CAUTION! Do not apply mechanical force on the parts during installation.

Requirements for horizontal and non-vertical piping:

- Maximum distance between brackets of 1 m.
- On tensile joints; maximum distance between brackets of 2 m.

Follow the manufacturer's instructions.

- Spread the brackets evenly along the piping.

Requirements for vertical piping:

- Maximum distance between brackets of 2 m.
- Spread the brackets evenly along the piping.

Always place a bracket on or near a bend or elbow piece, except if the flue pipes before and after the elbow piece are shorter than 0,25 m. In this case, fix the second element after the elbow with a bracket.

Every flue discharge system needs to be secured with at least one bracket. The first bracket needs to be within the first 0,5 m of the air heater.

When installing a flue system inside a shaft, do the following:

1. Check the components for possible damage or blockage.
2. Check that the pipe is at the right slope (see Requirements).
3. Mark the flue pipes and fresh air pipes to avoid mixing them up.
4. Make sure that the pipes extend for at least 50 mm when passing through a wall or other obstacle.
5. Fix the last element before entering the shaft in place. If the last element is an elbow piece, the next element must also be fixed in place.
6. Check if ventilation openings and inspection hatches comply with national and local regulations.

6. Operating the air heater

6.1. Burner cycle

The air heater's display shows the current status of the burner cycle (figure 23).

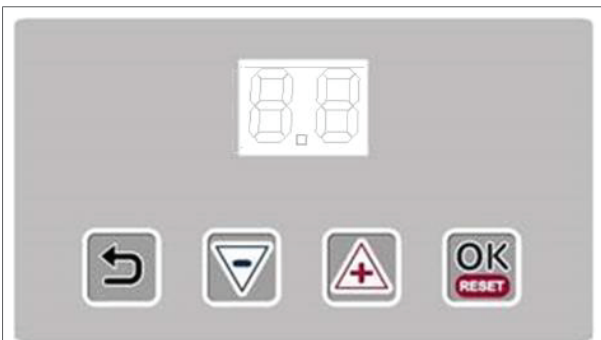

Figure 23 - Display of the air heater

Display	Status	Description
0	Stand-by	Waiting for heat demand.
1	Reset	Software reset.
3	Pre-check	Zero position check pressure switch.
4	Pre-purge	30 seconds of pre ventilation by the combustion fan. The pressure switch is checked.
5	Pre-ignition	Ignition without opening the gas valve.
6	Ignition	5 seconds of ignition. The gas valve opens.
7	Flame check	The air heater checks if the flame is present.
8	Burn	The heater fires up and starts to modulate.
9	Minimum	Before the flame stops, the burner will modulate to minimum power.
10	Burner off	The gas valve closes. The flame stops.
11	Post purge	Burner fan purges with fresh air. System fan cools the heat exchanger.

6.2. Minimum firing time

The heater will always fire for a minimum of 4 minutes, even if the heat demand stops. This is to avoid a large amount of start and stops and to prevent condensate from accumulating in the flue system.

NOTICE The heater will try to ignite 2 times before it stops and gives an error.

6.3. Delta-T-regulation

The air heater can function as a de-stratification fan. This is called delta-T regulation and it is done via the room thermostat, with a temperature measurement sensor that is located on the air heater.

The system fan is activated when the temperature-difference between the sensor on the heater (the delta-T NTC sensor) and the sensor in the thermostat is bigger than 12 °C (standard factory setting). This procedure ensures an even distribution of temperature throughout the building, thus acting as a fully automatic de-stratification fan.

6.3.1. Switch off delta-T-regulation

Delta-T regulation can be switched off when it is not desired (e.g. when it causes discomfort). This can be done in the **Settings** menu on the room thermostat. See the user manual of the special Room thermostat for more information.

NOTICE Delta-T regulation is automatically switched off when the delta-T sensor (sensor terminal J6) is disconnected.

6.4. Summer ventilation

The fan can be set to run in the summer. Follow the instructions in the user manual of the special Room thermostat.

6.5. Overheating protection

The air heater's heat exchanger and flue system are both protected from excessive temperatures.

6.5.1. Heat exchanger

An NTC sensor is located near (or on) the heat exchanger. This sensor monitors the heat exchanger temperature.

If the heat exchanger becomes too hot, this sensor will cause the heating process to stop. Depending on the temperature, the air heater performs the following actions:

- Step 1: Power reduction (when possible).
- Step 2: Burner stop, followed by an automatic restart when cooled down (display: E05 / E36).
- Step 3: Burner stop, followed by a Lock Out. A manual reset is required. (display L15).

NOTICE A manual reset can be done on the electronic circuit board or remotely with the special room thermostat.

6.5.2. Flue system

The flue sensor (NTC) is an optional component that is located in the flue system of the air heater. This sensor monitors the flue temperature.

If the flue system becomes too hot, this sensor will cause the heating process to stop. Depending on the temperature, the heater performs the following actions:

- Step 1: Power reduction (when possible).
- Step 2: Burner stop, followed by an automatic restart when cooled down.
- Step 3: Burner stop, followed by a Lock Out. A manual reset is required. (display L16).

6.6. Flue passage check

The air heater is equipped with a pressure switch that checks the passage of combustion air through the heat exchanger. The pressure switch checks if there is sufficient movement of combustion air through the heat exchanger (only during the pre-purge phase). If the pressure difference is too low, the air heater will not start. Error L-14 will be shown on the display.

7. Commissioning the air heater

7.1. Adjusting the settings

Prior to packaging, the safety and functioning of each air heater is checked in detail. It is also set to the right combustion efficiency.

In general, the heater does not need to be adjusted after installation. It is only necessary to perform a functional check and to obtain a flue gas analysis and record it for later reference.

CAUTION! Always adjust the burner settings of the heater using the manual test mode (see §7.2.2.). Do not use the thermostat to adjust the burner settings.

CAUTION! Use only calibrated instruments to adjust the air heater.

CAUTION! Never carelessly turn the adjuster screws.

NOTICE Adjusting the control without a supporting flue gas analysis voids the warranty.

Only adjust the CO₂ value if the CO₂ reading differs more than 0,2% from its setting. O₂ value ± 0,3%.

7.2. Commissioning the air heater

Once the unit is installed according to this manual, the unit can be commissioned. To do so, follow these instructions:

1. Make sure the gas supply pipe is clean, gas tight and free from air.
2. Switch on the electric supply with the maintenance switch.

You are now able to observe the first start-up and become familiar with the functioning of the heater.

NOTICE If the gas line is not purged correctly, the heater will attempt to start twice before going into a lock-out condition. In this case, manual reset is necessary.

1. Instruct the end user of the about a safe use of the air heater:
 - The presence of gas
 - The location of the manual gas valve
2. Instruct the end user about the operation of the heater:
 - Lock-out indication
 - Reset

3. Instruct end user about the necessary maintenance.
4. Leave this manual with the end user.

7.2.1. First use – thermostat

To commission the air heater via the room thermostat, do the following:

- Put the thermostat in the highest position. The start sequence is always the same.

The air heater will burn for the minimal firing time (see §6.2. for more information).

7.2.2. First use - display

To commission the air heater via the display's manual test mode, do the following:

NOTICE The display's manual test mode will only work for maximum 10 minutes.

1. Press and hold the **Return** and (–) button for a few seconds (figure 24). The display will alternate between Lo and St. This means the heater will start up in Low fire.
2. Press the (+) and (–) buttons to toggle between Low and High fire (figure 24).
3. Press the (–) button until 0 is displayed to exit the service. The air heater will always cool down the heat exchanger for several minutes.

The test mode will automatically end after 10 minutes.

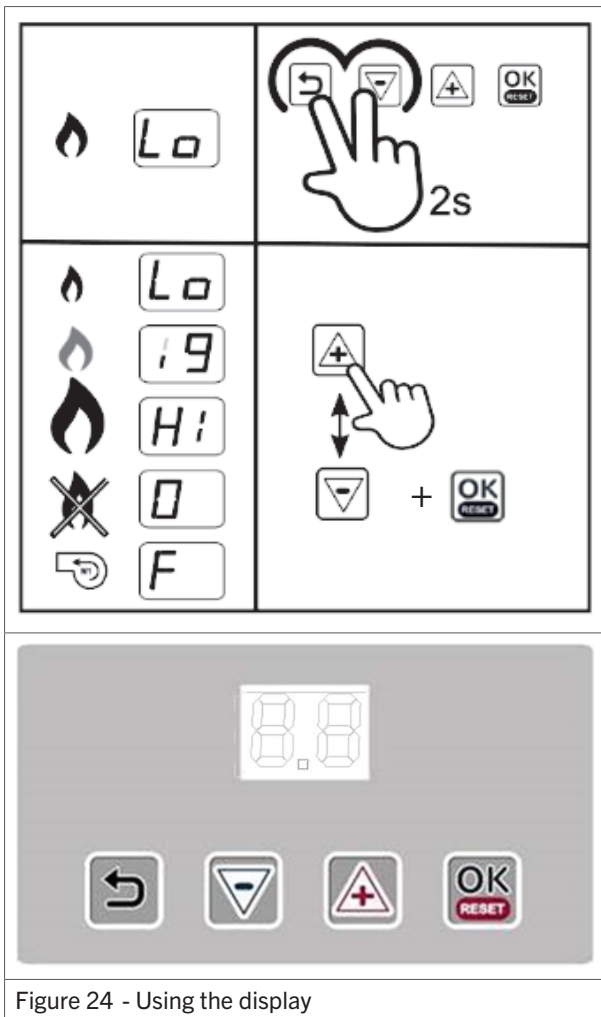

Figure 24 - Using the display

8. Combustion settings

In principle, it is not necessary to adjust the gas valve shortly after commissioning the air heater. When the control does have to be adjusted after a period of use or after installing a new heater, this must be done by a qualified person using calibrated equipment.

DANGER! A poor adjustment can lead to overheating of the air heater and/or production of toxic carbon monoxide.

CAUTION! Always adjust the burner settings of the heater using the manual test mode (see §7.2.2.). Do not use the thermostat to adjust the burner settings.

1. Shut-off solenoid valve (EV1)	7. Shut-off solenoid valve (EV2)
2. Offset adjuster screw	8. Pilot outlet
3. Pilot gas flow restrictor	9. Main gas outlet
4. Gas/air adjuster screw	10. Holes for fixing flanges (M5)
5. Inlet pressure test point	11. Supplementary valve body fixing points
6. Outlet pressure test point*	12. Air in signal

8.1. Adjusting the burner settings

The flow of gas to the burner is controlled with a gas valve. This valve must be set to the high and a low power settings of the heater. When adjusting, the CO₂ or O₂ in flue gas has to be monitored with a calibrated analyser.

The gas valve is adjusted with two screws (figure 25):

- The Offset adjuster screw for Low fire.
- The Gas/air adjuster screw for High fire.

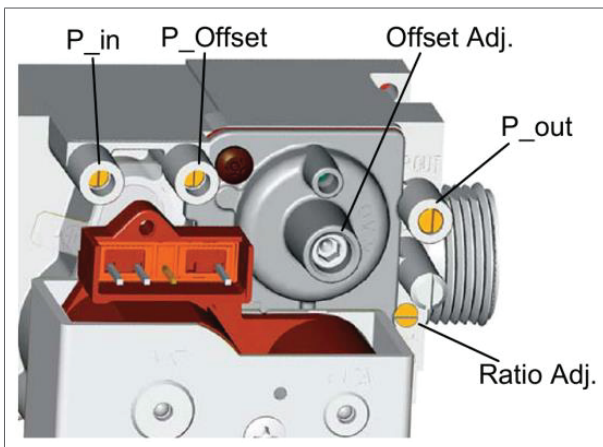

Figure - Main parts of the gas valve XR10+ - XR60+

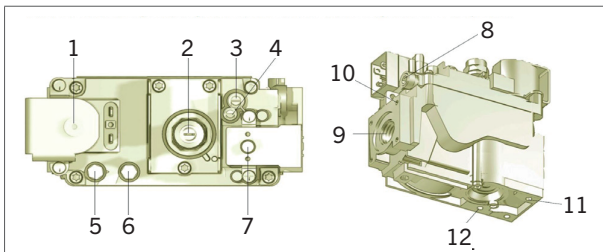

Figure 25 - Main parts of the gas valve XR80+ - XR100+

The air heater must first be commissioned at High fire.

NOTICE If the air heater does not ignite while sparking, close the air-openings of the gas-air mixer during ignition. Use your forefinger. The gas mixture will become richer and will ignite more easily.

Look for the correct CO₂ value for the air heater in §3.2.. Adjust the CO₂ value if the difference is more then 0,2%, O₂ value ± 0,3%.

1. Check the CO₂ value in High fire (mode 4).
2. Turn the Ratio adjuster screw to the right to decrease the CO₂ value.
3. Turn the Ratio adjuster screw to the left to increase the CO₂ value.
4. Check the CO₂ value in Low fire (mode 2). The CO₂ value in Low fire should be lower than in High fire.
5. Turn the Offset adjuster screw to the left to decrease the CO₂ value.
6. Turn the Offset adjust screw to the right to increase the CO₂ value.
7. Return to High fire (mode 4) and readjust the CO₂ value with the Ratio adjust screw.
8. Return to Low fire (mode 2) and readjust the CO₂ value with the Offset adjuster screw.
9. Repeat the steps above until both CO₂ values are ok.

DANGER! Always measure the air heater's CO production. Too much CO usually means the gas mixture is too rich. Adjust this if necessary with the two adjusters (figure 25). The concentration of CO should always be below 100 ppm.

8.2. Converting to another gas type

CAUTION! The air heater's gas type may only be converted by the manufacturer or its representative. Contact your supplier for more information.

9. Troubleshooting

If the air heater malfunctions, first check if the problem is caused by external circumstances (e.g. no supply power). If the problem is not caused by external circumstances, use the tables and instructions in this chapter to fix the air heater.

NOTICE Please remember the built in waiting times of the air heater; the signals of the LED's and the code on the display. Do not react too soon.

9.1. Volatile lock outs

The table below describes the volatile lock outs that can occur. These can only be reset by hand.

Display	Error type	Description	Case #
L-0	Internal error	Internal error	13
L-1	Ignition error	Flame lasts only 5 seconds after ignition	1
		No flame after ignition	2
L-2 and 3	Internal error	Internal error	13
L-4	E-error	E-error for more than 24 hours	12
L-5	Burner fan error	Burner fan does not work	6
L-6 and 7	Burner fan error	Burner fan rotates at the wrong speed	7
L-8 to 12	Internal error	Internal error	13
L-13	Pressure switch error	Pressure switch is closed in stand-by mode	14
L-14	Pressure switch error	Pressure switch does not close during pre-purge	11
L-15	Overheating	Heat exchange sensor is overheated	3
L-16	Flue temperature error	Flue sensor is overheated	3
L-17 to 19	Internal error	Internal error	13
L-20	Flame error	Flame detected after closing the gas valve	15
L-21	Flame error	Flame detected before opening the gas valve.	16
L-22	Flame error	Flame failure during burning	5
L-25	Sensor error	Heat exchange sensor failure	4
L-26	Sensor error	Flue sensor failure	4
L-27 to 31	Internal error	Internal error	13
L-32	Sensor error	Heat exchange sensor failure	4
L-33 to 38	Internal error	Internal error	13
L-42	Flue temperature error	Too many flue temperature errors	3
L-43	Overheating	Heat exchange sensor is overheated too often	3

9.2. Temporary errors

The table below describes the temporary errors that can occur. These will disappear automatically after the cause has been resolved.

Display	Error type	Description	Case #
E-00 to 04	Internal error	Internal error	13
E-05	Overheating	Heat exchange sensor is overheated	3
E-06 to 13	Internal error	Internal error	13
E-14	Flame error	Flame detected when there shouldn't be one	16
E-15 to 19 and 22	Internal error	Internal error	13
E-20 and 21	Heat exchanger sensor error	Heat exchanger sensor not detected	4
E-23 and 24	Flue sensor error	Flue sensor not detected	4
E-27 and 28	Heat exchanger sensor error	Heat exchanger sensor short-circuit	4
E-30 and 31	Flue sensor error	Flue sensor short-circuit	4
E-34	Reset button error	Too many reset actions in a short timespan	9
E-36	Overheating	Heat exchange sensor is overheated	3
E-38 and 39	Heat exchanger sensor error	Heat exchanger sensor not detected	4
E-47 and 48	Heat exchanger sensor error	Heat exchange sensor short-circuit	4
E-49 to 64	Internal error	Internal error	13
E-65	Voltage too low	Supply voltage is too low for over 1 minute	
E-66	Voltage too high	Supply voltage is too high for over 1 minute	
E-67	Pressure switch error	Too many pressure switch errors	11
E-68	Flue temperature error	Flue sensor is overheated	3
E-69	Configuration error	Heater configuration error	19

9.3. Warnings

The table below describes the temporary warnings that can occur. The heater may still be working, or stops until the cause has been resolved.

Display	Error type	Description	Case #
A-02	Configuration error	Heater configuration error	19
A-07	Overheating	Heat exchange sensor is almost overheated	3
A-08	Overheating	Flue sensor is almost overheated	3

9.4. Instructions

After identifying the problem, use the Case number to find the possible cause in this paragraph.

Case 1: Flame lasts only 5 seconds after ignition.

- The flame is not detected:
 - Check the ignition/ionisation cable and the electrode. The cable should have a resistance of 1 kΩ.
- The air heater is not earthed properly.
- The circuit board is defective.

Case 2: No flame after ignition.

- There is not enough gas pressure.
- The gas mixture is too poor:
 - Adjust the gas valve (see §8.1.).
- The gas valve does not open:
 - During ignition, check for a 230 V voltage on the valve.
- Check if the ignition electrode sparks. If not:
 - Check the cable and electrode and replace them when damaged.
 - Check the burner control unit and replace it when it does not give a spark output.

Case 3: Heat exchange sensor or flue sensor is overheated.

- Check if the connectors J12 and J6 are plugged in correctly and if the connection J12[1-4] (optional overheating protection) is closed.
- Check if the system fan supplies enough air.
- Check the settings of the gas valve. The heater may be overfired. If so:
 - Adjust the burner pressure.

Case 4: Heat exchange sensor or flue sensor not detected, or short circuit.

NOTICE L-25 refers to the heat exchange sensor. L-26 refers to the flue sensor, if applicable.

- The heat exchange sensor consists of two internal sensors. The readings of these sensors may differ too much:
 - Measure the resistance of each sensor. The resistance should be 20 kΩ at 25 °C and 25 kΩ at 20 °C.
 - If the measured values differ too much, replace the sensor.

Case 5: Too many flame failures while burning.

- The gas supply is not constant. This results in a drop in gas supply pressure while burning and causes the flame to extinguish.
 - Check the gas supply pressure while the heater is burning.

- The burner pressure for Low fire is too low. This causes the flame to extinguish because it is too small to be detected.
 - Check the burner pressure at Low fire and adjust if necessary (see §8.1).
- Recirculation of flue gas. Due to a problem with the flue terminal the flue gas is sucked back into the air inlet. This results into a lack of oxygen and causes the flame to stop.
 - Check the flue system and fresh air supply. Only certified, original parts should be used.

Case 6: Burner fan does not work.

- Check if the burner fan is blocked.
- Check if the wiring is damaged.
- The burner fan is defective.

Case 7: Burner fan rotates at the wrong speed.

- Check if the burner fan runs smoothly.
- Check if the wiring is damaged.

Case 9: Too many reset actions in a short timespan.

- This error will disappear after some time or if the main power is disconnected for a while.

Case 11: Insufficient air passage through the heat exchanger. Pressure switch does not close.

- Check if the combustion fan is running.
- Check if the flue system is blocked or restricted.
- Check the pressure switch and the connections.
- Check the heat exchanger for flue leakage.

Case 12: E-error for more than 24 hours.

- Switch the air heater off and on and check the error code.

Case 13: Internal error.

- Isolate the electrical supply and reenergise. If this does not help:
 - Replace the burner control unit.

Case 14: Pressure switch is closed in stand-by mode.

- Check if the contact is stuck. If so:
 - Replace the pressure switch.
- Check if there is water in the hose. If so:
 - Dry the hose.

Case 15: Flame detected after closing the gas valve.

- Check if the gas valve closes too slow. If so:
 - Replace the gas valve.
- Check if the ionisation electrode is wet. If so:
 - Dry, clean or replace the electrode.

Case 16: Flame detected before opening the gas valve.

- Check if there really is a flame before ignition. If so:
 - Replace the gas valve.
- Check if the ionisation electrode is wet. If so:
 - Dry, clean or replace the electrode.

Case 19: Heater configuration error

- The heater does not know which program to run, due to a mismatch between the burner control unit and the display. If so:
 - Contact your supplier.

9.5. Further troubleshooting

When the air heater does start but shows a different problem than described above, check if the following problems apply.

9.5.1. Explosive ignition and/or frequent flame failures

- Check if the gas control settings are correct (see §8.1). A correct CO₂ value is important for a proper ignition.
- Check the ignition cable. It should have a resistance of 1 kΩ.

- Check the position of the ignition electrode. The spark has to be formed between the two electrodes, not between the electrode and the burner.

9.5.2. Insufficient output

The heat output of the air heater is insufficient if there is too much resistance in the inlet or outlet flue system. The burner fan still rotates at full speed, but the resistance prevents enough gas mixture from entering the burner.

- Check the flue system for blockage.
- Check the burner for dust or other pollution.

9.5.3. Non modulating system fan

System fan (M1) sometimes does not start or does not vary in speed.

- Check the functioning of this fan by connecting it to a supply of 230 V.
- Check if the fan is energised. Use a multi-meter. If so, the cause of the problem lies in the burner control unit.

10. Maintenance

CAUTION! The air heater must be inspected and cleaned once a year by a qualified installer with sufficient knowledge about the device.

CAUTION! Sufficient maintenance is critical in circumstances such as high humidity, dust, high switching on/off frequency, etc.

10.1. Preparation

Before performing maintenance on an air heater that is already installed, do the following:

1. Set the thermostat to the lowest setting.
2. Close the manual gas valve.
3. Turn off the power supply to the air heater using the maintenance switch.

CAUTION! Always check for gas leaks after working on the air heater.

CAUTION! Do not use water when cleaning the air heater.

CAUTION! The heater must be electrically isolated during servicing.

10.2. Basic maintenance

To perform basic maintenance on the air heater, do the following:

CAUTION! When cleaning parts of the air heater, use a dry cloth, brush, compressed air or a vacuum cleaner. Never use a steel brush.

1. Inspect the outside of the heat exchanger.
2. Clean the fan guard on the outside of the heater. Clean the fan blades if required.
3. Open the access panel.

4. Clean the inside of the air heater. Focus on the following parts:
 - Body
 - Fan blades and motor
 - Heat exchanger
 - Temperature sensor
 - Vane switch (if present)
5. Check if the wiring, nuts and bolts are properly secured and tightened.
6. Grease any parts and bolts that are regularly loosened for maintenance.
7. Open the manual gas valve in the supply line and check if the supply lines are air tight, do not leak and do not contain air.

Some checks can only be performed when the heater is running. Do the following:

1. Reconnect the air heater to the power supply.
2. Switch on the air heater.
3. Check if the heater operates without problems. See §9. if any errors occur.
4. Check the air heater's combustion efficiency. If necessary:
 - Adjust the burner settings (see §8.1.).

10.3. Maintenance of the burner unit

The burner unit is an important part of the air heater and requires special maintenance.

To perform maintenance on the burner unit, do the following:

1. Remove the gas pipe between the gas valve and the combustion fan.
2. Remove the ignition and fan wires.
3. Unscrew the socket screws (M6).
4. Remove the burner unit from the air heater, complete with flange and pre-mix fan.
5. Disassemble the burner unit.
6. Adjust the ignition electrode:
 - a. The distance between the electrode and the burner should be $5.0 (\pm 0.5)$ mm (figure 26).
 - b. The distance between the two electrodes should be $3.6 (\pm 0.4)$ mm (figure 27).
 - c. Check the setting of the ignition electrode. The spark should be formed between the two electrodes, not between the electrode and the burner.

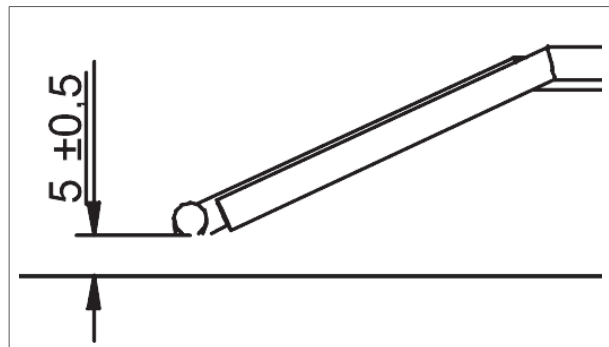

Figure 26 - Distance between the electrode and the burner

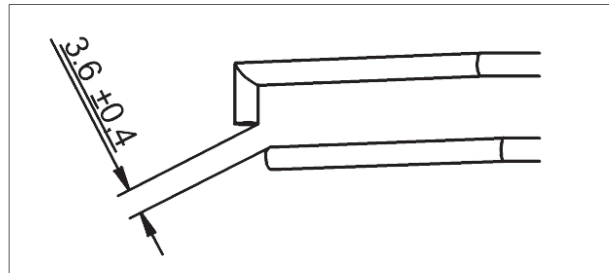

Figure 27 - Distance between the two electrodes

7. Reassemble the burner unit and install it back in the air heater.
 - Use new gaskets.

11. Electrical wiring diagram

A complete electrical wiring diagram is shown in figure . The connections that are most important to the installation process are shown in figure 30.

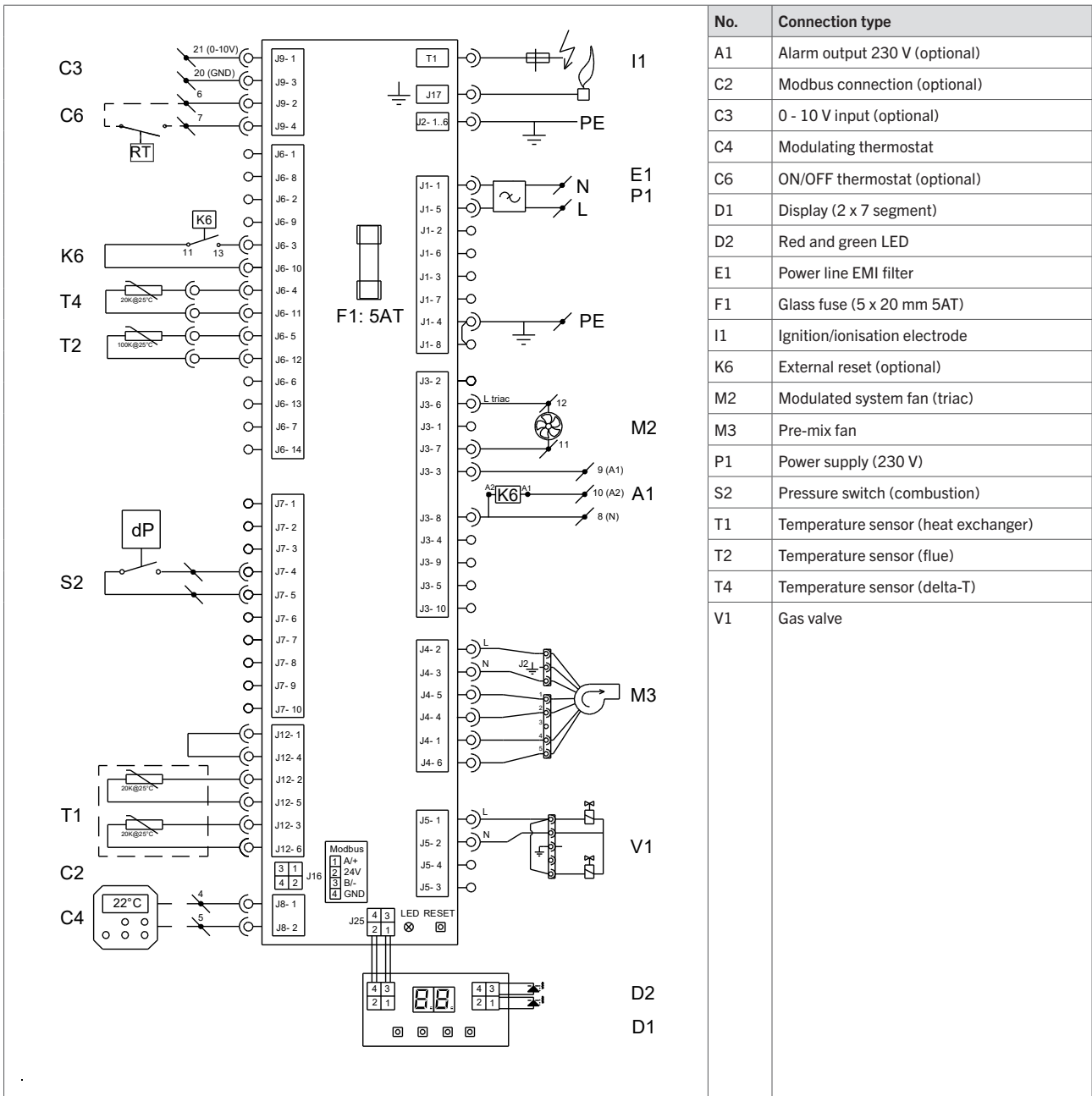

Figure 28 - Electrical wiring diagram XR10+ - XR60+

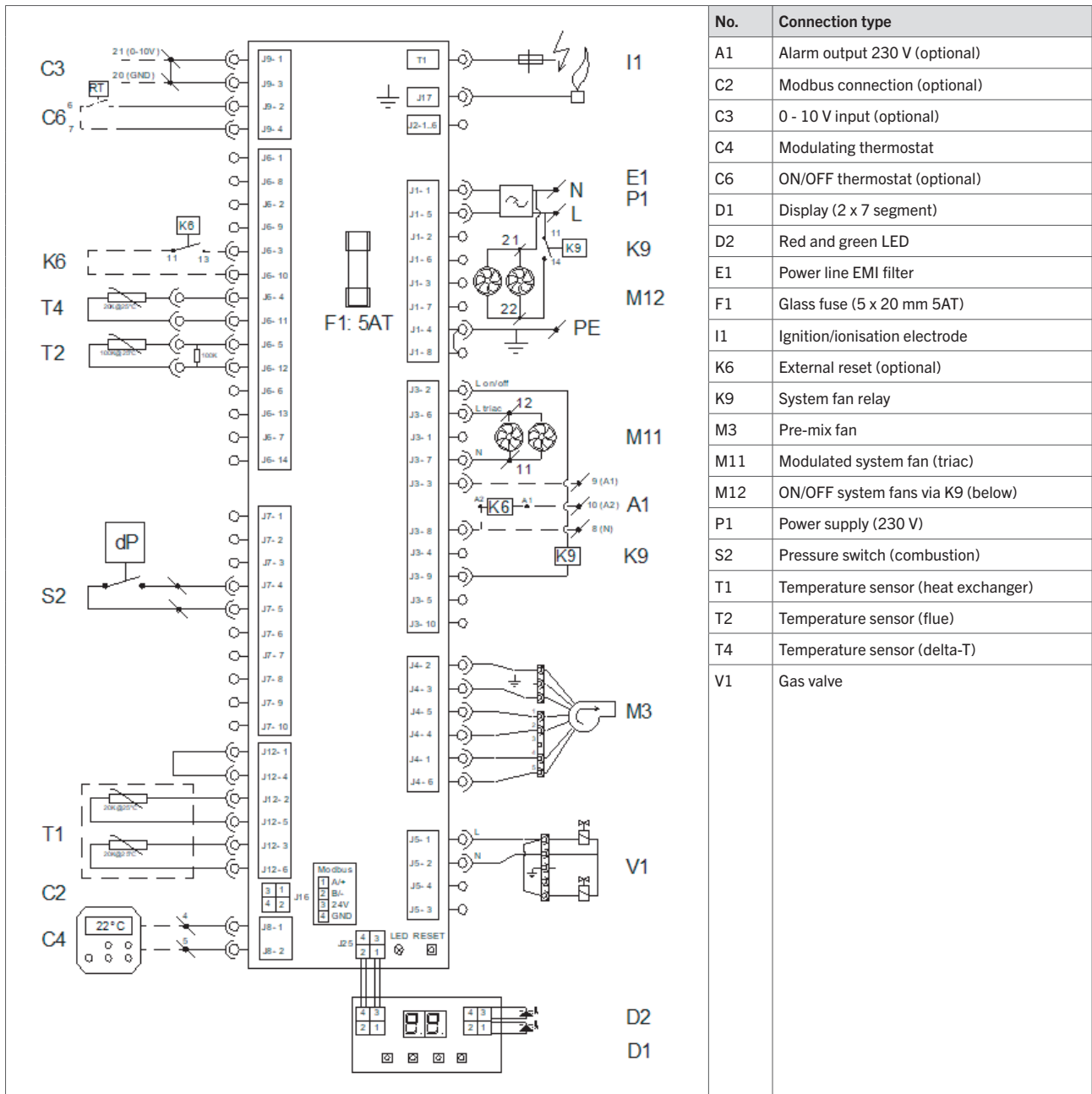

Figure 29 - Electrical wiring diagram XR80+ - XR100+

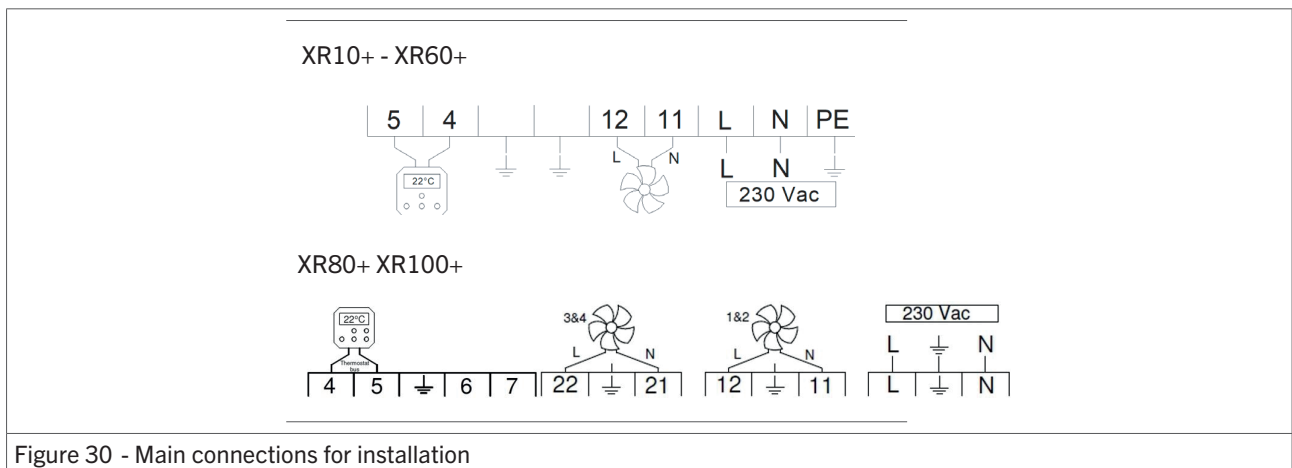

Figure 30 - Main connections for installation

12. Exploded view and spare parts

The parts of the air heater are shown in an exploded view in figure 31. The table below describes each part and shows the correct article number for a replacement part.

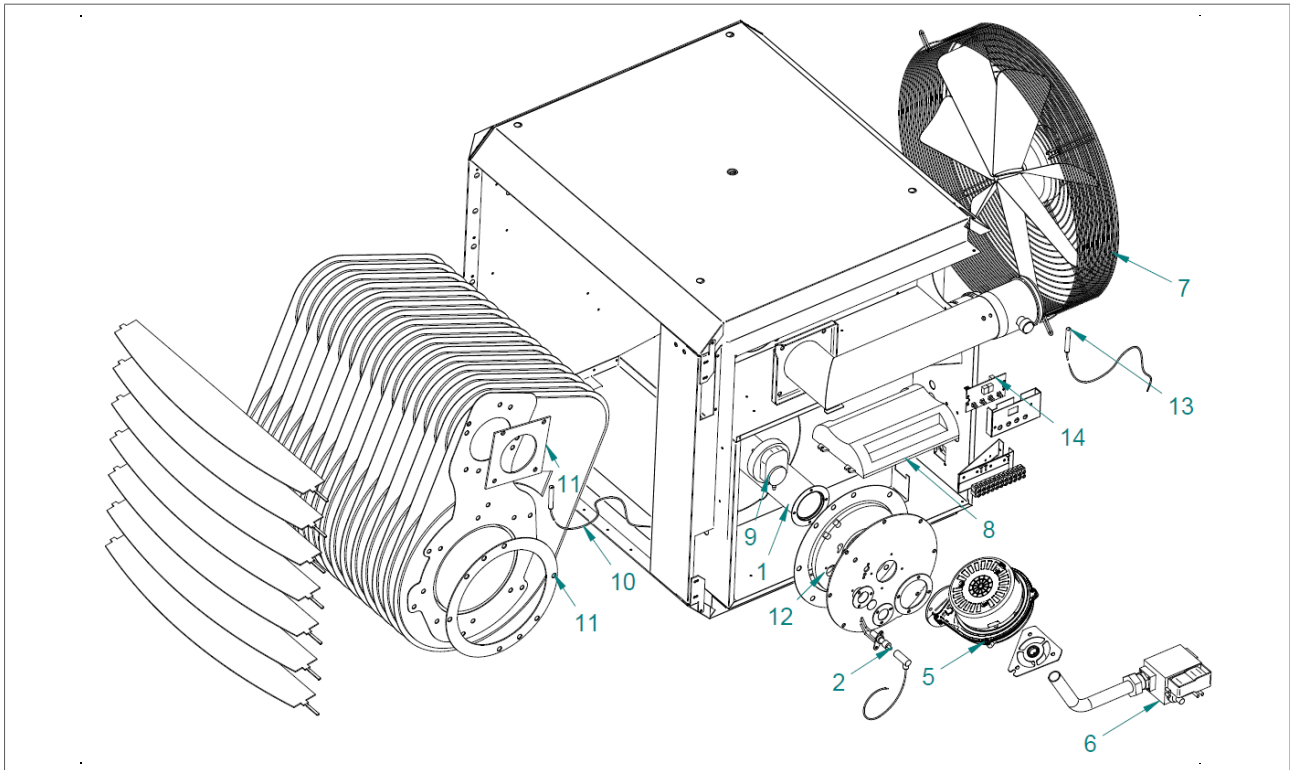



Figure 31 - Exploded view of the XR10+ - XR100+

No.	Description	XR10+	XR20+	XR30+	XR40+	XR50+	XR60+	XR80+	XR100+
1	Burner natural gas	GA3206	GA3207	GA3208	GA3210	GA3210	GA3212	GA3232	GX3214
1	Burner propane	GA3224	GA3226	GA3228	GA3230	GA3230	GA3232	GA3232	GX3214
2	Ignition / ionisation set	GA3460	GA3460	GA3460	GA3460	GA3460	GA3460	GA3460	GA3460
5	Burner fan	GY4523	GY4523	GY4523	GY4523	GY4523	GY4523	IY4502	IY4502
6	Gas valve	GA3000	GA3000	GA3000	GA3000	GA3000	GA3000	GY3002	GY3002
7	System fan	GX4201	GX4204	GX4204	GX4206	GX4217	GX4217	GX4212 (4x)	GX4214 (4x)
8	Burner control unit (EBM966)	GY5901	GY5901	GY5901	GY5901	GY5901	GY5901	GY5901	GY5901
9	Pressure switch	GX3932	GX3932	GX3932	GX3932	GX3932	GX3932	GX3932	GX3932
10	Heat exchange sensor	GY3932	GY3932	GY3932	GY3932	GY3932	GY3932	GY3933	GY3933
11	Gasket set	GA6702	GA6702	GA6702	GA6706	GA6706	GA6706	GA6707	GA6707
12	Burner isolation	GA6700	GA6700	GA6700	GA6704	GA6704	GA6704	IX6731	IX6730
13	Delta-T sensor	GY3931	GY3931	GY3931	GY3931	GY3931	GY3931	GY3931	GY3931
14	Display PCB	GY5902	GY5902	GY5902	GY5902	GY5902	GY5902	GY5902	GY5902
15	Flue sensor XR	GX3931	GX3931	GX3931	GX3931	GX3931	GX3931	GX3931	GX3931

13. Disposal and recycling

	<p>The meaning of the symbol on the material, its accessory or packaging indicates that this product shall not be treated as household waste. Please, dispose of this equipment at your applicable collection point for the recycling of electrical and electronic equipments waste. In the European Union and Other European countries which there are separate collection systems for used electrical and electronic product. By ensuring the correct disposal of this product, you will help prevent potential hazards to the environment and to human health, which could otherwise be caused by unsuitable waste handling of this product. The recycling of materials will help conserve natural resources. Please do not therefore dispose of your old electrical and electronic equipment with your household waste.</p>
---	---

14. Declaration of conformity

Winterwarm Heating Solutions B.V.
Industrieweg 8
7102 DZ, Winterswijk
The Netherlands

Declares that air heater types:

- XR10+, XR20+, XR30+, XR35+, XR40+, XR50+, XR60+, XR80+ and XR100+
- CE PIN: 0063B03156

Are in accordance with the essential requirements of the relevant EU directives, being:

- 2016/426/EU (GAR) relating to appliances burning gaseous fuels
- 2014/35/EU (LVD) relating to the electric safety of appliances
- 2014/30/EU (EMC) relating to electromagnetic compatibility of appliances
- 2006/42/EG (MD) relating to the safety of machinery

Goods should be installed and used in accordance with our instructions and with the applicable local and international rules. Installation should be done by an authorized, qualified and competent installer.

Winterswijk, December 23rd 2021



Ir. M. Fiselier
Director of Operations

