

Installation manual

Air heater

Type DHX



Contents

1. Introduction	3	7. Commissioning the air heater	14
1.1. Symbols used in this manual	3	7.1. Adjusting the settings	14
1.2. Warranty	3	7.2. Commissioning the air heater	14
2. Safety instructions	4	8. Combustion settings	17
2.1. Installation	4	8.1. Adjusting the burner settings	17
2.2. Use	4	8.2. Converting to another gas type	18
2.3. Maintenance & Cleaning	4	9. Troubleshooting	19
2.4. Children and vulnerable users	5	9.1. Volatile lock outs	19
3. Technical specifications	6	9.2. Temporary errors	19
3.1. Performance	6	9.3. Warnings	19
3.2. Gas types	6	9.4. Instructions	20
3.3. Dimensions	8	9.5. Further troubleshooting	21
4. Installation	9	10. Maintenance	22
4.1. Preparation	9	10.1. Preparation	22
4.2. Positioning the air heater	9	10.2. Basic maintenance	22
4.3. Gas type & connection	9	10.3. Maintenance of the burner unit	22
4.4. Electrical connection	10	10.4. Extensive maintenance in poultry sheds	23
4.5. Room thermostat	10	11. Electrical wiring diagram	24
5. Flue systems	12	12. Exploded view and spare parts	25
6. Operating the air heater	13	13. Disposal and recycling	26
6.1. Burner cycle	13	14. Declaration of conformity	26
6.2. Minimum firing time	13		
6.3. Summer ventilation	13		
6.4. Overheating protection	13		
6.5. Air passage check	14		
6.6. Gas supply pressure	14		

1. Introduction

This manual is intended for the gas, electrical and mechanical installer.

This document gives instructions on how to use and maintain the air heater. It is most important to follow the instructions in this document for safe operation of this air heater.

It is important to read this document before starting the installation process. Store this document close to the air heater for quick reference.

1.1. Symbols used in this manual

DANGER! Indicates a dangerous situation that would lead to death or severe injury.

WARNING! Indicates a potentially dangerous situation that could lead to death, severe injury or serious product damage.

CAUTION! Indicates a potentially dangerous situation that could lead to injury or product damage.

NOTICE Indicates important information that is not directly related to safety.

1.2. Warranty

NOTICE Using, installing or maintaining this air heater in any other way than described in this manual may cause damage that voids the warranty.

NOTICE Failing to follow the safety instructions in this manual can lead to damage to the air heater or the installation and void the warranty.

2. Safety instructions

Always follow the safety instructions in this chapter when installing, using or performing maintenance on this air heater:

2.1. Installation

CAUTION! This air heater must be installed and maintained by an authorized, qualified and competent installer, using calibrated equipment.

NOTICE This air heater must be installed and maintained in accordance with this manual, national and local building regulations and local health and safety regulations.

2.1.1. Protection against dust

CAUTION! Cover the air heater while spreading sawdust on the floor. This prevents large amounts of dust from accumulating on the heater.

CAUTION! The air heater can be used in a dusty environment (e.g. a poultry shed) if they are cleaned and maintained more frequently.

2.1.2. Temperature

CAUTION! Do not install the heater in places where the temperature can rise above 40°C. Higher temperatures cause the internal components to degrade much faster.

2.1.3. Corrosive vapours

WARNING! Do not install the air heater in areas that contain any corrosive or explosive vapours. Corrosive vapours (e.g. containing Chlorine) that are sucked into the air intake will cause corrosion of the heat exchanger and a leakage of condensate and flue gas. This is also the case for the room thermostat.

2.2. Use

CAUTION! Make sure the area around the air heater is dry when performing maintenance on the air heater.

CAUTION! Always close the doors and inspection hatches of the air heater, except when adjusting and checking the appliance.

2.2.1. Maximum CO₂ concentrations

This air heater uses oxygen from the surrounding air for the combustion process. CO₂ is formed and emitted as a result. Too much CO₂ in the air may be harmful to people, animals and crops.

DANGER! Never allow the CO₂ concentration to rise above the values shown in the table below!

	Maximum CO ₂ concentration	
Poultry shed	0.3%	3,000 ppm
Greenhouse	1%	10,000 ppm

DANGER! This air heater may emit carbon monoxide (CO) when the oxygen level in the surrounding air is too low. Carbon monoxide is extremely dangerous. Ensure sufficient ventilation to prevent this from happening.

WARNING! The minimal ventilation requirements for a room in which this air heater is installed is 1000 m³/h for each 100 kW of installed power.

2.3. Maintenance & Cleaning

Frequent maintenance and cleaning of the air heater is necessary to ensure safe and proper operation. Failure to do so could lead to damage to the heater or its surroundings and void the warranty.

CAUTION! Air heaters installed in a dusty and/or wet environment must be maintained and cleaned more frequently.

CAUTION! Air heaters installed in poultry sheds must be maintained and cleaned after every cycle.

CAUTION! Always have a service technician inspect and maintain the heater every year for reliable and safe operation.

2.3.1. Protection from water (IP class)

WARNING! Never use water when cleaning electrical parts.

This air heater is protected against splash water and has an IPX4D classification.

WARNING! Do not use a pressure washer to clean parts that contain electronics, such as the electric motor or the machine cover.

2.3.2. Disinfecting fluids

CAUTION! Some aggressive disinfection fluids can damage the heater. When using such fluids, cover the heater while disinfecting the shed.

2.4. Children and vulnerable users

WARNING! This air heater can be used by children aged 8 years and above and by persons with reduced physical, sensory or mental capabilities or lack of experience and knowledge, if they are supervised or instructed concerning use of the appliance in a safe way and understand the hazards involved.

WARNING! Children shall not play with the air heater.

WARNING! Children shall not clean and maintain this air heater without supervision.

3. Technical specifications

3.1. Performance

Technical specification	Unit	Type DHX v5.1			
		DHX40	DHX75	DHX100	DHX120
Net nominal heat input	kW	40.0	72.0	100.0	120.0
Heat output	kW	40.0	72.0	100.0	120.0
Air output	m ³ /h	3900	3900	5900	6800
Throw horizontal	m	43	43	51	51
Gas connection	G"	3/4"	3/4"	3/4"	3/4"
Electrical connection (50 Hz)	V	230	230	230	230
Electrical power consumption	kW	0.16	0.16	0.24	0.24
Stand-by electrical power consumption	kW	4	4	4	4
Electrical current (max.)	A	1.0	1.0	1.6	1.6
Protection class	-	IPX4D			
Pressure switch point	mbar	15	15	15	15
Sound level (at 8 m)	dBA	65	65	70	70
Thermostat connection	-	2-wire low voltage communication bus or ON/OFF 230 V			
Net weight	kg	35	35	45	45

3.2. Gas types

3.2.1. Natural gas G20

Specification	Unit	Natural gas G20			
Nominal supply pressure	mbar	20			
Supply pressure (min. - max.)	mbar	17-25			
Gas category	-	II ₂ H ₃ B/P DE: II ₂ ELL ₃ B/P BE: I ₂ Er FR: II ₂ Er ₃ B/P NL: II ₂ EK ₃ B/P			
Pressure switch point	mbar	15			
Class	-	A3			
Specification	Unit	DHX40	DHX75	DHX100	DHX120
Gas consumption	m ³ /h	4.2	7.5	10.3	12.3
Burner injectors	n x Ømm	1x 5.85	1x 8.5	1x 10.5	1x 12.0
Burner pressure	mbar	8.0	6.5	6.3	6.0

3.2.2. Butane / LPG G30

Specification	Unit	Butane / LPG G30			
Nominal supply pressure	mbar	30 / 50			
Supply pressure (min. - max.)	mbar	20-50			
Gas category	-	II ₂ H ₃ P B/P NL: II ₂ EK ₃ B/P DE: II ₂ ELL ₃ B/P BE: I ₃ B/P FR: II ₂ Er ₃ B/P PL: II ₂ ELwLs ₃ B/P			
Class	-	A3			
Specification	Unit	DHX40	DHX75	DHX100	DHX120
Gas consumption	kg/h	4.0	6.0	8.0	9.5
Burner injectors	n x Ømm	1 x 4.5	1x 5.85	1x 6.85	1x 7.8
Burner pressure	mbar	8.5	8.0	9.0	8.1

3.2.3. Propane G31

Specification	Unit	Propane G31			
Nominal supply pressure	mbar	30 / 50			
Supply pressure (min. - max.)	mbar	20-50			
Gas category	-	II ₂ H ₃ P B/P NL: II ₂ EK ₃ B/P DE: II ₂ ELL ₃ B/P BE: I ₃ B/P FR: II ₂ Er ₃ P PL: II ₂ ELwLs ₃ B/P			
Class	-	A3			
Specification	Unit	DHX40	DHX75	DHX100	DHX120
Gas consumption	kg/h	3.8	5.7	7.9	9.5
Burner injectors	n x Ømm	1 x 4.5	1x 5.85	1x 6.85	1x 7.8
Burner pressure	mbar	11.5	10.7	11.5	10.7

3.3. Dimensions

The dimensions of this air heater can be found in figures 1 through 2.

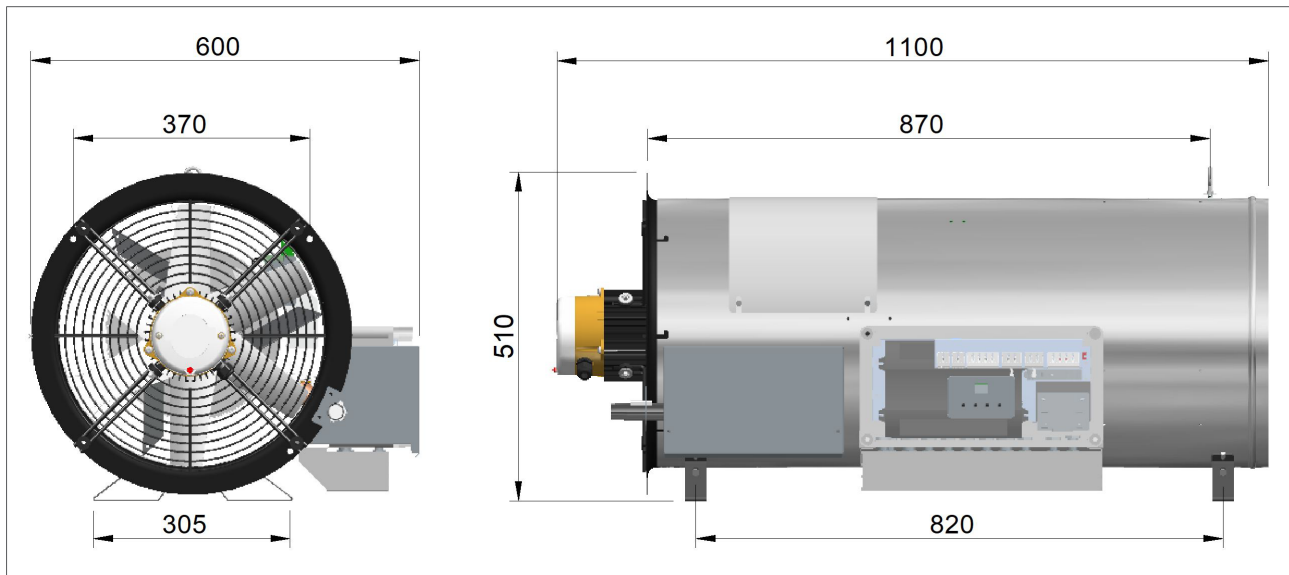

Figure 1 - Dimensions of the DHX40 - DHX75

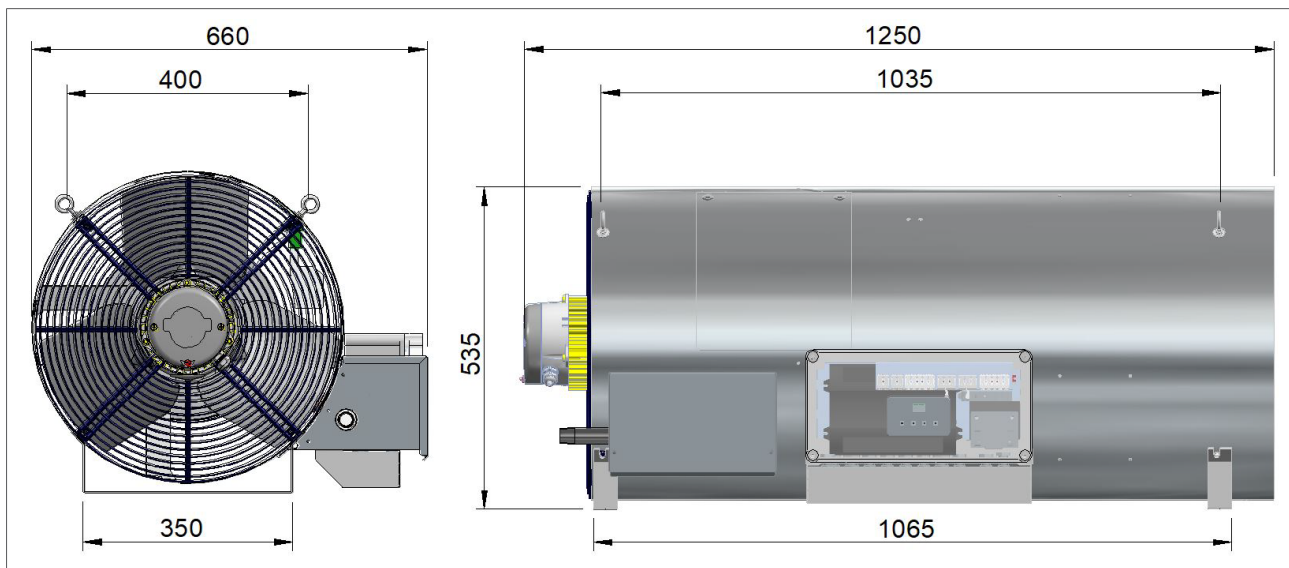

Figure 2 - Dimensions of the DHX100 - DHX120

4. Installation

4.1. Preparation

Before installation, please use the data badge to check:

- if the heater is in accordance with the order;
- if the heater is suitable for the local present provisions (gas type, gas pressure, electrical supply etc.)

Before leaving the factory, the air heater has been tested for safety and has been set to the operating settings. It has been configured for the type of gas that is stated on the data badge. Should there be any doubt about the settings that apply to your situation, please contact your supplier.

4.1.1. Standards

NOTICE The installation must comply with all applicable local and national standards.

NOTICE The air heater must be installed in accordance with the relevant requirements of the Gas Safety regulations, Electrical installation regulations and or other local regulations that may apply.

4.2. Positioning the air heater

Keep the following requirements in mind when choosing a location to install your air heater:

WARNING! Never install an air heater close to flammable materials.

- Keep sufficient distance between the heater and any obstructions. This is both for safety reasons and to allow access for service and maintenance (figure 3).
- Make sure the air flow to and from the heater is free from obstacles at least 5 metres in front of the heater. Also make sure the air intake is free from obstacles.
- Make sure enough space remains to open the door of the air heater.
- Make sure the wall can support the air heater.

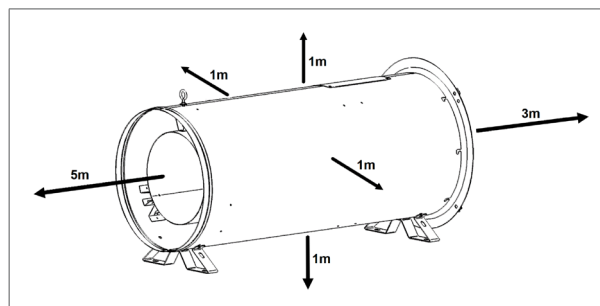

Figure 3 - Minimum clearances around the air heater

4.2.1. Orientation

- Install the heater horizontally without an inclination (figure 4).

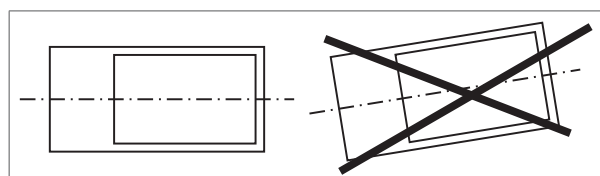

Figure 4 - A correct and incorrect horizontal orientation

4.3. Gas type & connection

The unit is suited for natural gas, propane or butane (LPG).

The specific gas type that a heater is set up for can be found on the packaging labels and on the heater badge.

The heater can be converted to another gas type. Contact your supplier for more information.

The working and standing supply pressure must be a minimum of 17 mbar, and a maximum of 50 mbar, measured at the inlet pressure nipple of the gas control in the heater.

NOTICE The supply line's manual isolation valve must be placed within reach of the heater.

NOTICE All gas supply lines must be mounted without any mechanical tension.

NOTICE Always clean the inside of a gas supply line before connecting it to the air heater. Place a gas filter in the supply line when needed.

CAUTION! When using pressures above 60 mbar to test the supply lines, always close the manual isolation valve of the air heater.

4.4. Electrical connection

The electrical installation must comply with local and national requirements as well as IEE regulations.

4.4.1. Power supply

The air heater requires an earthed power supply of 230 V / AC. The device is not phase-dependent. A supply of 400 V / AC + Neutral is optional. The control circuit is a two wire 230 V connection.

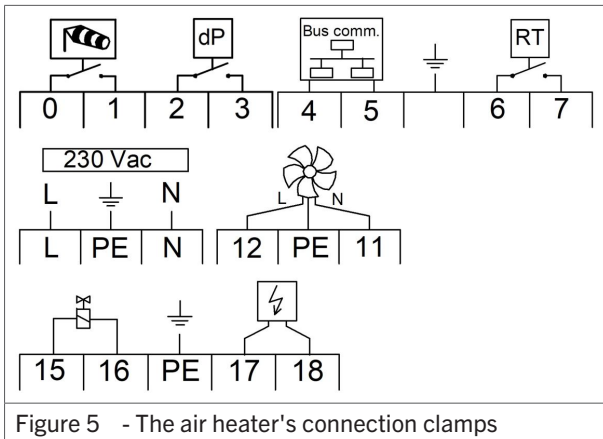

A supply cord with a connection plug is supplied with the air heater.

NOTICE Make sure you do not damage the supply cord. A damaged cable needs to be replaced by a qualified person immediately.

4.4.2. Fuse

One fuse is present on the air heater's control board (see the electrical wiring diagram in §11.).

- When replacing this fuse, always use one of the same type (5AT).

4.5. Room thermostat

The air heater can be controlled in two ways:

- by an ON/OFF signal 230 V;
- through a bus communication system with an external interface.

4.5.1. Installation requirements bus communication

Following these requirements when placing the thermostat to ensure the heater functions correctly:

- Make sure that air can circulate around the thermostat.
- Make sure the sun does not shine directly upon the thermostat.
- Do not place the thermostat on a cold wall.
- Place the thermostat on an inner wall free from draught.
- Never place the thermostat within the throw of the heater.
- Never mount the thermostat near the aerials of internal communication networks. These emit radiation that can disturb the thermostat. Keep several meters distance.

In all cases, the communication between the heater and the thermostat is based on a two wire, low-voltage connection. (see the electrical wiring diagram in §11.). Follow these instructions to prevent malfunction of the installation and damage to the thermostat or air heater:

- Use a cable with the following specifications:
 - Signal cable.
 - Shielded and twisted.
 - Minimum dimensions: 1 x 2 x Ø0.8 mm².
 - Maximum length: 200 m.

CAUTION! Keep the thermostat cable separated from the mains cables.

CAUTION! Connect the cable's earth shield only to the earth terminal inside the air heater. Do not connect the other end of the cable's earth shield.

NOTICE A cable with a thickness of less than 0.8 mm will result in a poor signal.

NOTICE A cable that is not shielded and twisted may result in a disturbed communication in an EMC-unfriendly environment.

4.5.2. Bus communication system installation

To connect the air heater to a bus communication system, do the following:

1. Connect the two control wires to terminals 4 and 5 (see figure 6 or the electrical wiring diagram in §11.).
2. Set the S1 and J14 switches on the control unit as follows (figure 7 / 8):
 - a. Set S1 to 1.
 - b. Set J14 to 1.

NOTICE The air heater must be switched off when setting the switches. Otherwise the settings will have no effect.

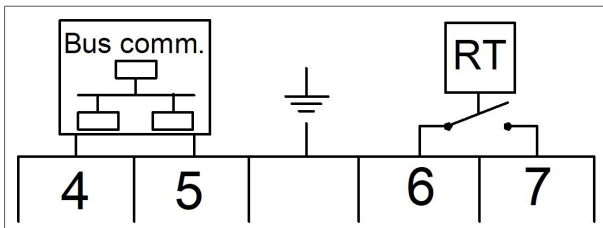

Figure 6 - Bus communication connection

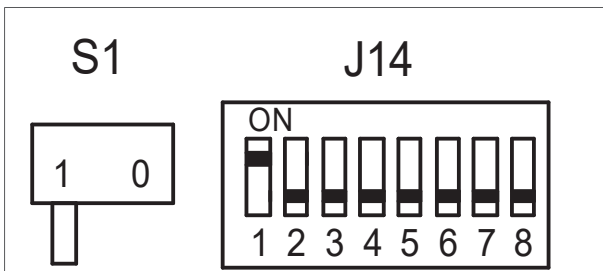

Figure 7 - Positions of the S1 and J14 switches

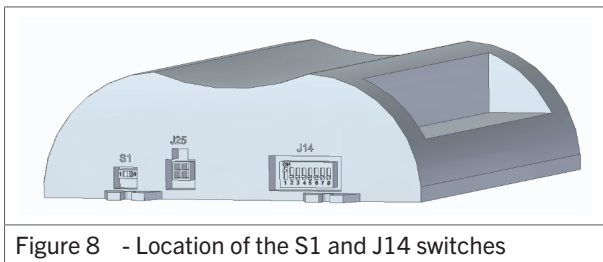

Figure 8 - Location of the S1 and J14 switches

4.5.3. Installation of multiple heaters on one control unit

An MTC or MTS room thermostat, or interface module can control up to 8 air heaters. To connect the air heaters, do the following (figure 9):

NOTICE This functionality does not apply to an ON/OFF thermostat.

1. Connect the two wires of the thermostat to terminals 4 and 5 of the first air heater.
2. Connect the first air heater to the second air heater.
3. Repeat for each subsequent air heater.

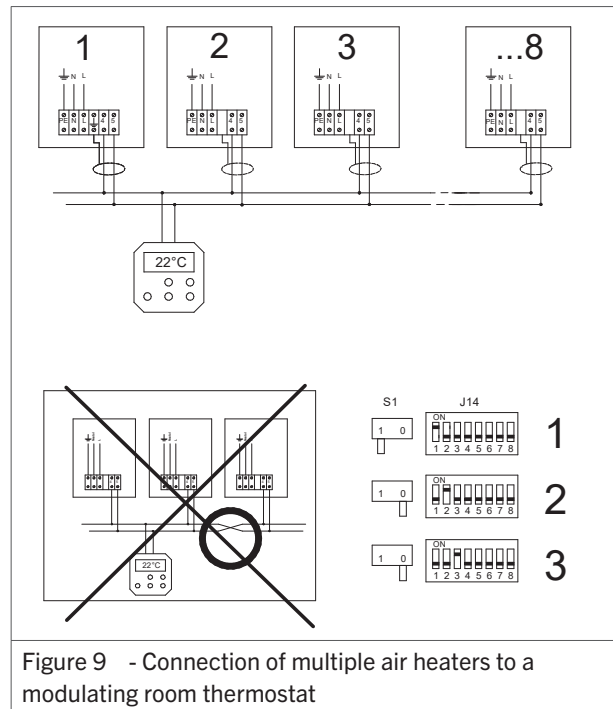

Figure 9 - Connection of multiple air heaters to a modulating room thermostat

Each air heater needs an unique number to be recognised by the room thermostat. This number can be set with the J14 switch on the control unit of each air heater:

1. Set the S1 and J14 switches on the control unit as follows (figure 10):
 - a. Set the S1 switch of the first air heater to 1.
 - b. Set the S1 switch of the other air heaters to 0.
 - c. Set the J14 switch of the first air heater to 1.
 - d. Set the J14 switch of the second air heater to 2, etc.

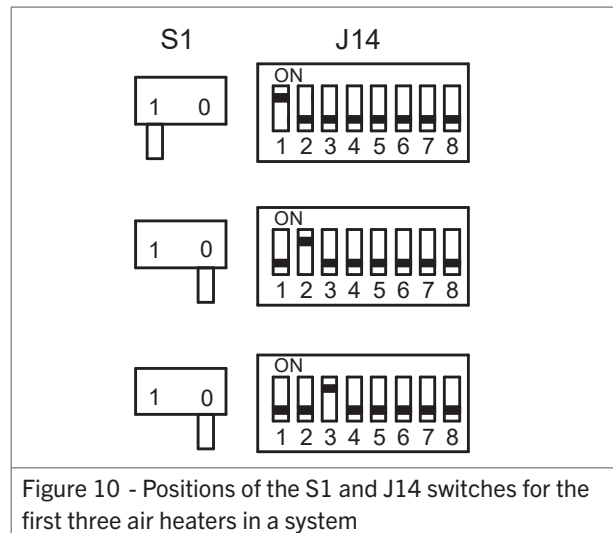

Figure 10 - Positions of the S1 and J14 switches for the first three air heaters in a system

NOTICE If the J14 switch of more than one air heater is set to the same number, the system will not work.

NOTICE The air heater must be switched off when setting the switches. Otherwise the settings will have no effect.

4.5.4. ON/OFF thermostat installation

To connect the air heater to an ON/OFF room thermostat, do the following:

- Connect the two thermostat wires to terminal 6 and 7 (see figure 11 or the electrical wiring diagram in §11.). This is a 230 V connection for the thermostat signal.

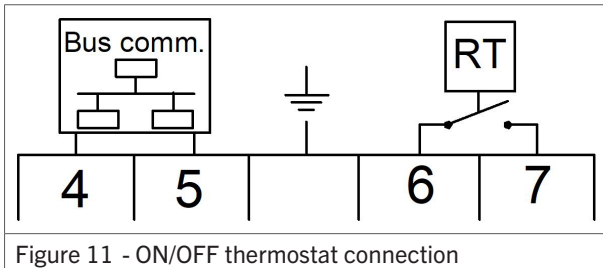

5. Flue systems

To ensure safe and proper use, this air heater must be connected to a flue system. This flue system must be installed according to this manual as well as national and local regulations. A flue system consists of a flue terminal, piping and an optional condensate discharge system.

DANGER! Never allow the CO₂ concentration to rise above the values shown in the table below!

	Maximum CO ₂ concentration	
Poultry shed	0.3%	3,000 ppm
Greenhouse	1%	10,000 ppm

DANGER! This air heater may emit carbon monoxide (CO) when the oxygen level in the surrounding air is too low. Carbon monoxide is extremely dangerous. Ensure sufficient ventilation to prevent this from happening.

WARNING! The minimal ventilation requirements for a room in which this air heater is installed is 1000 m³/h for each 100 kW of installed power.

6. Operating the air heater

6.1. Burner cycle

The air heater's display shows the current status of the burner cycle (figure 12).

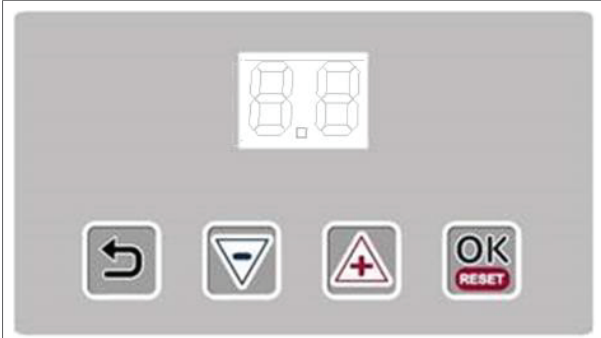

Figure 12 - Display of the air heater

Display	Status	Description	Time (seconds)
0	Stand-by	Waiting for heat demand.	-
1	Reset	Software reset.	-
3	Pre-check	Zero position check pressure switch.	-
4	Pre-purge	10 seconds of pre-ventilation by the fan. The pressure switch is checked.	10
5	Pre-ignition	Ignition without opening the gas valve.	-
6	Ignition	5 seconds of ignition. The gas valve opens.	-
7	Flame check	The air heater checks if the flame is present.	-
8	Burn	The heater fires up and burns.	15
9	Minimum (if applicable)	Before the flame stops, the burner will modulate to minimum power.	-
10	Burner off	The gas valve closes. The flame stops.	-
11	Post purge	System fan purges with fresh air. System fan cools the heat exchanger.	40 - 120
P	Anti-shuttle	The heater can not generate a heat demand during this period.	1
F	Ventilation	Request to start (summer) ventilation mode.	-

6.2. Minimum firing time

The heater will always fire for a minimum of 15 seconds, even if the heat demand stops. This is to avoid a large amount of start and stops.

NOTICE The heater will try to ignite 2 times before it stops and gives an error.

Enter the times below in the barn computer to match the heat demand and the fire cycle of the air heater.

Burner cycle phase	Duration (seconds)	
	Minimum value	Maximum value
Pre purge time	10	10
Firing time	15	3600*
Post purge time	40	120

*The air heater will restart after every hour.

6.3. Summer ventilation

The fan can be set to run in the summer. Follow the instructions in the user manual of the Room thermostat or the Bus communication system.

Summer ventilation can be activated on the air heater. For further information, see §7.2.3..

6.4. Overheating protection

An NTC sensor is located near (or on) the heat exchanger. This sensor monitors the heat exchanger temperature.

If the heat exchanger becomes too hot, this sensor will cause the heating process to stop. Depending on the temperature, the air heater performs the following actions:

- Step 1: Power reduction (when possible) (display: A07).
- Step 2: Burner stop, followed by an automatic restart when cooled down (display: E05 / E36).
- Step 3: Burner stop, followed by a Lock Out. A manual reset is required. (display L15).

NOTICE A manual reset can be done on the electronic circuit board or remotely with the special room thermostat.

6.5. Air passage check

The air heater is equipped with a vane switch to check the passage of air through the heater. If the air passage is too low, the heater will stop. Error L-14 will be shown on the display.

6.6. Gas supply pressure

The gas supply pressure during stand-by and operation should be between certain values, depending on the gas type:

Natural gas: between 17 and 30 mbar.

Propane & Butane: between 25 and 57 mbar.

When the supply pressure is too low, the heater will not work. Error A-09 will be shown on the display. The setting from the pressure switch is shown in the technical specifications (chapter 3.).

WARNING! When the supply pressure is too low, the combustion gasses may become harmful for humans, as well as animals and crops.

NOTICE When multiple heaters start at the same time, the gas pressure may drop. When the gas pressure restores, the heater will automatically restart.

Gas type	Unit	Gas supply pressure	
		Minimum value	Maximum value
Natural gas	mbar	17	30
Propane & Butane	mbar	25	57

7. Commissioning the air heater

7.1. Adjusting the settings

Prior to packaging, the safety and functioning of each air heater is checked in detail. It is also set to the right combustion efficiency.

In general, the heater does not need to be adjusted after installation. It is only necessary to perform a functional check and to obtain an optional flue gas analysis and record it for later reference.

CAUTION! Use only calibrated instruments to adjust the air heater.

CAUTION! Never carelessly turn the adjuster screws.

NOTICE Adjusting the control without checking the burner pressure voids the warranty.

Only adjust the burner pressures if they differ more than 0,5 mbar from its setting.

7.2. Commissioning the air heater

Once the unit is installed according to this manual, the unit can be commissioned. To do so, follow these instructions:

1. Make sure the gas supply pipe is clean, gas tight and free from air.
2. Switch on the electric supply with the maintenance switch.

You are now able to observe the first start-up and become familiar with the functioning of the heater.

NOTICE If the gas line is not purged correctly, the heater will attempt to start twice before going into a lock-out condition. In this case, manual reset is necessary.

1. Instruct the end user of the about a safe use of the air heater:
 - The presence of gas
 - The location of the manual gas valve
2. Instruct the end user about the operation of the heater:
 - Lock-out indication
 - Reset
3. Instruct end user about the necessary maintenance.
4. Leave this manual with the end user.

7.2.1. First use – thermostat

To commission the air heater via the room thermostat, do the following:

- Put the thermostat in the highest position. The start sequence is always the same.

The air heater will burn for the minimal firing time (see §6.2. for more information).

7.2.2. First use - display

To commission the air heater via the display's manual test mode, do the following:

NOTICE The display's manual test mode will only work for maximum 10 minutes.

1. Press and hold the OK and (+) button for two seconds (figure 13). The display will alternate between Hi and St.
2. Press the OK button to confirm. The air heater will start a burner cycle.
3. Press the (-) button until 0 is displayed to exit the service. The air heater will always cool down the heat exchanger for several minutes.

The test mode will automatically end after 10 minutes.

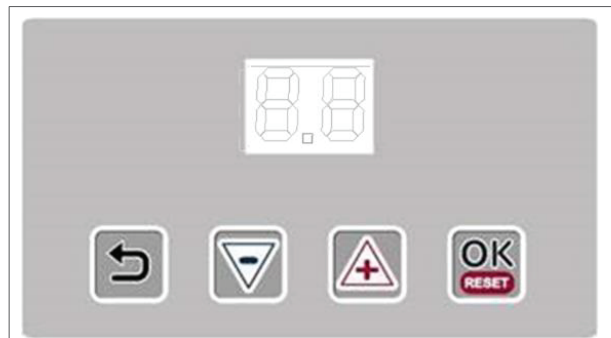
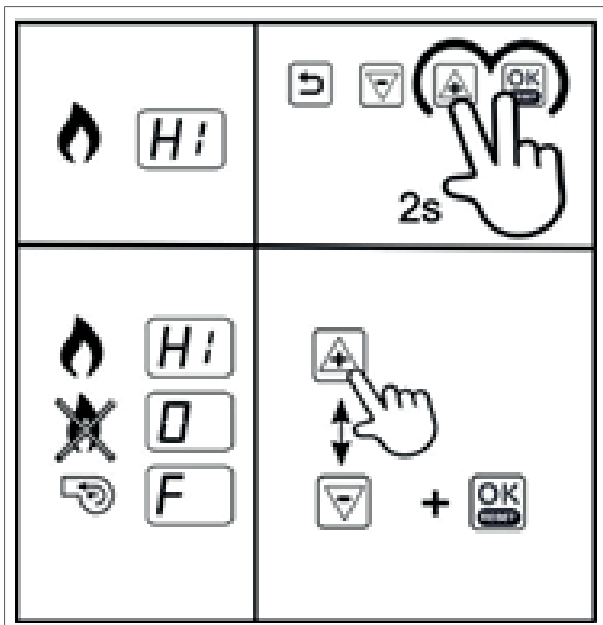

Figure 13 - Using the display

7.2.3. Manual operation

The air heater can be operated without an external thermostat or signal. There are three modes available:

Heat demand deactivated

When this mode is activated, the air heater does not respond to heat demands, except for heat demands received through bus communication.

To activate the heat demand deactivated mode, do the following:

1. Press the (+) and (-) buttons (figure 14) simultaneously. The display shows a blinking 0.
2. Press the (+) button until the display shows a blinking 6.
3. Press the OK button to deactivate the heat demands. The display shows H.

12 hour burner cycle

When this mode is activated, the air heater starts a burner cycle of 12 hours.

To activate a 12 hour burner cycle, do the following:

1. Press the (+) and (-) buttons (figure 14) simultaneously. The display shows a blinking 0.
2. Press the (+) button twice until the display shows a blinking 7.
3. Press the OK button to activate the 12 hour burner cycle mode. The display shows H2.

Summer ventilation

When this mode is activated, the air heater ventilates continuously. The air heater does not respond to heat demands. When a heat demand ends, the ventilation function continues.

To activate the summer ventilation, do the following:

1. Press the (+) and (-) buttons (figure 14) simultaneously. The display shows a blinking 0.
2. Press the (+) button three times until the display shows a blinking 8.
3. Press the OK button to activate the summer ventilation. The display shows H3.

Exit a mode

To deactivate a mode, do the following:

1. Press the (+) and (-) buttons (figure 14) simultaneously.
2. Press the (-) button until the display shows 0.
3. Press the OK button to deactivate the mode.

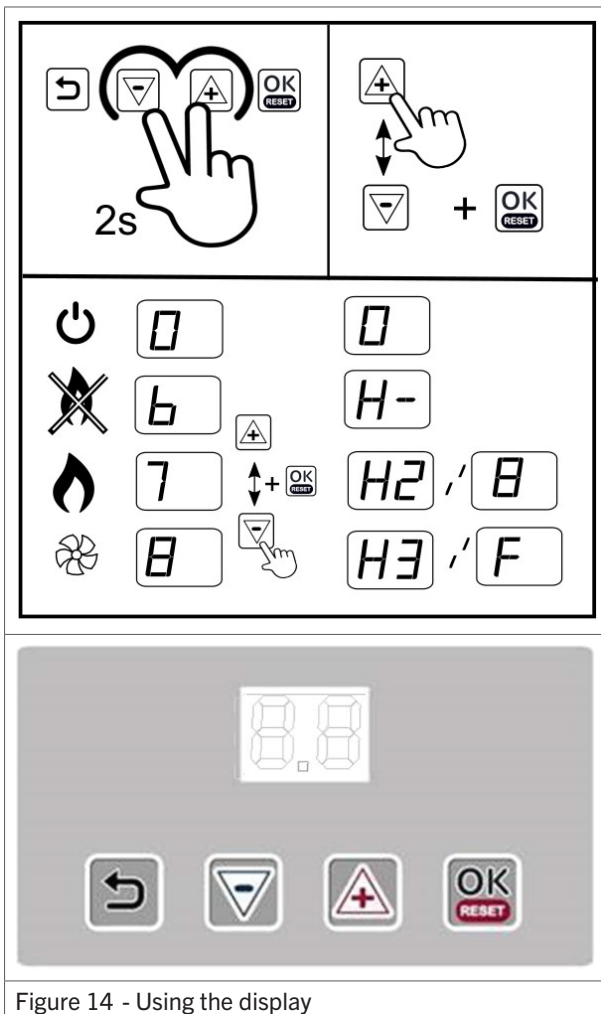

Figure 14 - Using the display

8. Combustion settings

In principle, it is not necessary to adjust the control shortly after commissioning the air heater. When the control does have to be adjusted after a period of use or after installing a new heater, this must be done by a qualified person using calibrated equipment.

DANGER! A poor adjustment can lead to overheating of the air heater and/or production of toxic carbon monoxide.

8.1. Adjusting the burner settings

The flow of gas to the burner is controlled with a gas valve. The valve must be set to the correct burner pressure. The minimum gas pressure switch is mounted on the right side of the measuring point (figure 15).

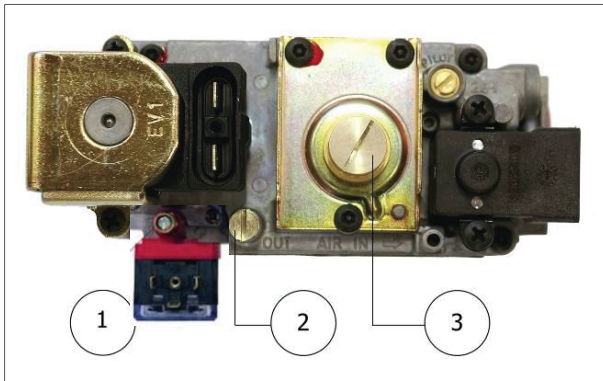

Figure 15 - Main parts of the gas valve

1	Measuring point of gas supply pressure.
2	Measuring point of burner pressure.
3	Adjuster screw for burner pressure.

To adjust the burner pressure, do the following:

1. Switch off the air heater.
2. Connect the pressure meter to the measuring point (figure 15 - 2).
3. Switch on the air heater and start heating.
4. Check whether the burner pressure is equal to the nominal burner pressure for this air heater (see §3.2.).
5. Record the measured value as a reference for the next measurement.
6. If the burner pressure does not correspond with the specified value, turn the adjuster screw (figure 15 - 3) to the specified value.

8.1.1. Measuring the CO₂ values

Adjusting the burner pressure using the adjusting screw is sufficient. Optionally, you can check the CO and CO₂ values, which can be done as follows.

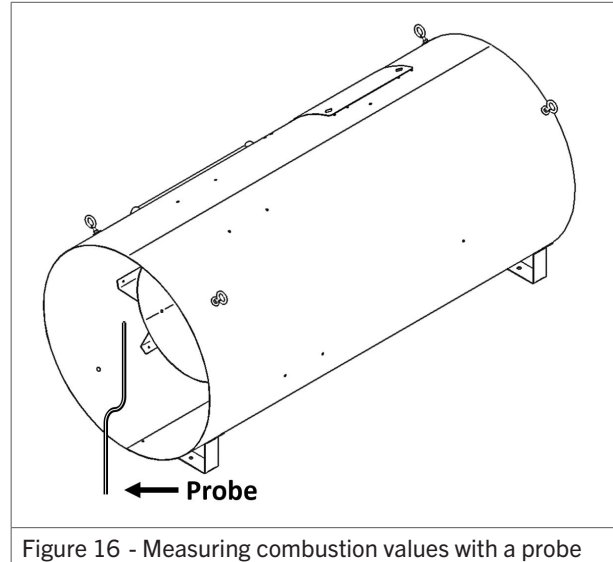

Figure 16 - Measuring combustion values with a probe

To measure the CO and CO₂ values, do the following:

1. Switch on the air heater and allow it to heat for about 5 minutes.
2. Measure the CO value.
3. Measure the CO₂ percentage in the flue gas.
4. Record the CO and the CO₂ values as a reference for the next measurement.
5. If the CO value exceeds 15 ppm:

or

If the CO₂ value does not correspond to the specified percentage (table A):

- a. Check the burner pressure air inlet opening of the system fan to see if the CO₂ value deviates by more than 1%.
- b. Measure the burner pressure (figure 15 - 2).
- c. Check whether the gas pipe diameter is too small (gas pressure too low).
- d. Repeat steps 2 till 4.

Table A shows the approximate nominal CO₂ percentages for the DHX models (air temperature 20°C):

Gas type	Nominal CO ₂ percentage			
	DHX40	DHX75	DHX100	DHX120
High calorific gas (G20)	7.3%	8.1%	8.0%	7.1%
Low calorific gas (G25)	7.8%	8.7%	8.3%	7.7%
Butane (G30)	8.1%	9.6%	9.7%	8.6%
Propane (G31)	8.5%	9.8%	9.4%	8.9%

Table A - CO₂ values per gas type and heater model

8.2. Converting to another gas type

To change the gas type of the heater, the gas injector has to be changed (figure 17 - 6).

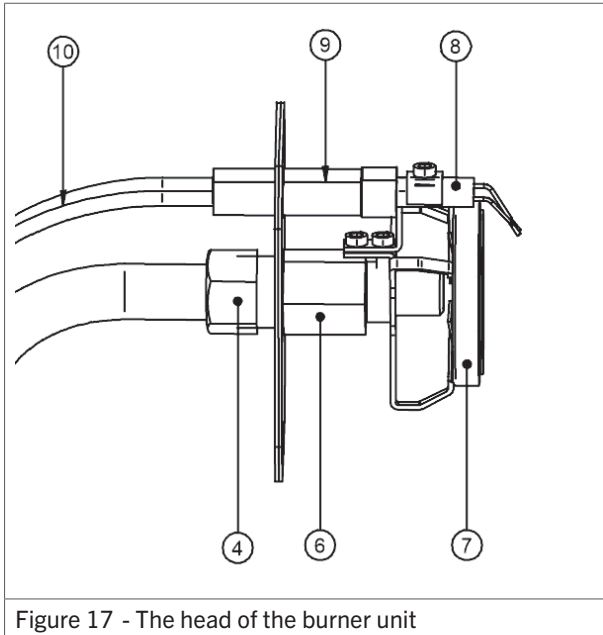

Figure 17 - The head of the burner unit

CAUTION! For safety reasons, the manufacturer recommends that the air heater is converted to another gas type only by the manufacturer, its representative or a qualified service technician. Contact your supplier for more information.

To change the gas injector, do the following:

1. Open the inspection hatch.
2. Remove the gas pipe by unscrewing the compression fitting (figure 17 - 4).
3. Remove the two connecting boots (figure 17 - 9) from the ignition electrode by gently pulling at the cables.
4. Unscrew the four nuts that connect the burner unit to the air inlet.
5. Remove the burner unit from the air heater.
6. Disassemble the burner unit:
 - a. Remove the stabilizer (figure 17 - 7) from the injector (figure 17 - 6).
 - b. Remove the flange from the injector by unscrewing the injector's nut.
7. Install the new injector.
8. Reassemble the burner unit.
9. Select the correct injector diameter and burner pressure (see §8.1.).
10. Change the labels on the air heater with ones that have the correct values for the new gas type.
11. When the air heater has been reassembled and cleaned, perform the following checks:
 - a. Open the manual gas valve and check if the gas supply line does not leak.
 - b. If the heater has been moved, check if the supply lines are connected properly.

WARNING! Gas supply lines that are not connected properly can slip off and create a fire hazard.

- c. Check if the wiring is secured properly.

12. Perform all checks that are performed during the installation of the air heater (see §7.2.):

- a. Measure the burner pressure.
- b. Measure the combustion values.
- c. Check the general heater operation.

9. Troubleshooting

If the air heater malfunctions, first check if the problem is caused by external circumstances (e.g. no supply power). If the problem is not caused by external circumstances, use the tables and instructions in this chapter to fix the air heater.

NOTICE Please remember the built in waiting times of the air heater; the signals of the LED's and the code on the display. Do not react too soon.

9.1. Volatile lock outs

The table below describes the volatile lock outs that can occur. These can only be reset by hand.

Display	Error type	Description	Case #
L-0	Internal error	Internal error	13
L-1	Ignition error	Flame lasts only 5 seconds after ignition	1
		No flame after ignition	2
L-2 and 3	Internal error	Internal error	13
L-4	E-error	E-error for more than 24 hours	12
L-8 to 12	Internal error	Internal error	13
L-13	Vane switch error	Vane switch is closed while fan isn't running	17
L-14	Vane switch error	Vane switch does not close when the fan should run	18
L-15	Overheating	Heat exchange sensor is overheated	3
L-17 to 19	Internal error	Internal error	13
L-20	Flame error	Flame detected after closing the gas valve	15
L-21	Flame error	Flame detected before opening the gas valve.	16
L-22	Flame error	Flame failure during burning	5
L-25	Sensor error	Heat exchange sensor failure	4
L-27 to 31	Internal error	Internal error	13
L-32	Sensor error	Heat exchange sensor failure	4
L-33 to 38	Internal error	Internal error	13
L-39	Vane switch error	Vane switch is closed while fan isn't running	17
L-40 and 41	Vane switch error	Vane switch does not close when the fan should run	18
L-43	Overheating	Heat exchange sensor is overheated too often	3

9.2. Temporary errors

The table below describes the temporary errors that can occur. These will disappear automatically after the cause has been resolved.

Display	Error type	Description	Case #
E-00 to 04	Internal error	Internal error	13
E-05	Overheating	Heat exchange sensor is overheated	3
E-06 to 13	Internal error	Internal error	13
E-14	Flame error	Flame detected when there shouldn't be one	16
E-15 to 20	Internal error	Internal error	13
E-21 and 22	Heat exchanger sensor error	Heat exchanger sensor not detected	4
E-27 and 28	Heat exchanger sensor error	Heat exchanger sensor short-circuit	4
E-34	Reset button error	Too many reset actions in a short timespan	9
E-36	Overheating	Heat exchange sensor is overheated	3
E-38 and 39	Heat exchanger sensor error	Heat exchanger sensor not detected	4
E-47 and 48	Heat exchanger sensor error	Heat exchange sensor short-circuit	4
E-49 to 64	Internal error	Internal error	13
E-65	Voltage too low	Supply voltage is too low for over 1 minute	
E-66	Voltage too high	Supply voltage is too high for over 1 minute	
E-67	Pressure switch error	Too many pressure switch errors	11
E-69	Configuration error	Heater configuration error	19

9.3. Warnings

The table below describes the temporary warnings that can occur. The heater may still be working, or stops until the cause has been resolved.

Display	Error type	Description	Case #
A-02	Configuration error	Heater configuration error	19
A-07	Overheating	Heat exchange sensor is almost overheated	3
A-09	Gas pressure	There is not enough gas pressure.	

9.4. Instructions

After identifying the problem, use the Case number to find the possible cause in this paragraph.

Case 1: Flame lasts only 5 seconds after ignition.

- The flame is not detected:
 - Check the ignition/ionisation cable and the electrode. The cable should have a resistance of 1 k Ω .
- The air heater is not earthed properly.
- The circuit board is defective.

Case 2: No flame after ignition.

- There is not enough gas pressure.
- The gas mixture is too poor:
 - Adjust the gas valve (see §8.1.).
- The gas valve does not open:
 - During ignition, check for a 230 V voltage on the valve.
- Check if the ignition electrode sparks. If not:
 - Check the cable and electrode and replace them when damaged. Optionally, verify the ionization value (see §9.5.2.).
 - Check the burner control unit and replace it when it does not give a spark output.
- Check the ignition transformer

Case 3: Heat exchange sensor or flue sensor is overheated.

- Check if the connectors J12 and J6 are plugged in correctly and if the connection J12[1-4] (optional overheating protection) is closed.
- Check if the system fan supplies enough air.
- Check the settings of the gas valve. The heater may be overfired. If so:
 - Adjust the burner pressure.

Case 4: Heat exchange sensor or flue sensor not detected, or short circuit.

NOTICE L-25 refers to the heat exchange sensor. L-26 refers to the flue sensor, if applicable.

- The heat exchange sensor consists of two internal sensors. The readings of these sensors may differ too much:
 - Measure the resistance of each sensor. The resistance should be 20 k Ω at 25 °C and 25 k Ω at 20 °C.
 - If the measured values differ too much, replace the sensor.

Case 5: Too many flame failures while burning.

- The gas supply is not constant. This results in a drop in gas supply pressure while burning and causes the flame to extinguish.
 - Check the gas supply pressure while the heater is burning.
- Recirculation of flue gas. Due to a problem with the flue terminal the flue gas is sucked back into the air inlet. This results into a lack of oxygen and causes the flame to stop.
 - Check the flue system and fresh air supply. Only certified, original parts should be used.

Case 9: Too many reset actions in a short timespan.

- This error will disappear after some time or if the main power is disconnected for a while.

Case 12: E-error for more than 24 hours.

- Switch the air heater off and on and check the error code.

Case 13: Internal error.

- Isolate the electrical supply and reenergise. If this does not help:
 - Replace the burner control unit.

Case 15: Flame detected after closing the gas valve.

- Check if the gas valve closes too slow. If so:
 - Replace the gas valve.
- Check if the ionisation electrode is wet. If so:
 - Dry, clean or replace the electrode.

Case 16: Flame detected before opening the gas valve.

- Check if there really is a flame before ignition. If so:
 - Replace the gas valve.
- Check if the ionisation electrode is wet. If so:
 - Dry, clean or replace the electrode.

Case 17: Vane switch is closed while fan isn't running

- Check if the vane switch is stuck and cannot go into the rest position. If so:
 - Clean or replace the vane switch.

Case 18: Vane switch does not close when the fan should run

- Check if the fan runs. If so:
 - Check if the vane switch is stuck and cannot go into closed position. If so:
 - Clean or replace the vane switch.
- If the fan does not run, check if the fan motor is powered. If not:
 - Replace the fan motor or the capacitor.

Case 19: Heater configuration error

- The heater does not know which program to run, due to a mismatch between the burner control unit and the display. If so:
 - Contact your supplier.

9.5. Further troubleshooting

When the air heater does start but shows a different problem than described above, check if the following problems apply.

9.5.1. Explosive ignition and/or frequent flame failures

- Check if the gas control settings are correct (see §8.1). A correct CO₂ value is important for a proper ignition.
- Check the ignition cable. It should have a resistance of 1 kΩ.
- Check the position of the ignition electrode. The spark has to be formed between the two electrodes, not between the electrode and the burner.

9.5.2. Checking the ionization value

The ionization value can be read on the display. To do this, do the following:

1. Press and hold the **return** button until the display shows 0.0/00.
2. Press the + button. The display shows 1.0/00.
3. Press the **OK** button. The display shows 1.0/01.
4. Press the + button until the display shows 1.0/08.
5. Press the **OK** button. The display shows the rounded ionization value (for example, 47 μA is displayed as 5 on the display).

During normal use, the display shows at least a value of 4.

10. Maintenance

CAUTION! The air heater must be inspected and cleaned once a year by a qualified installer with sufficient knowledge about the device.

CAUTION! Sufficient maintenance is critical in circumstances such as high humidity, dust, high switching on/off frequency, etc. In barns, a maintenance service is recommended after each cycle. Insufficient or irregular maintenance can lead to fire damage or damage to the air heater. Burning particles of dirt in the device can be expelled.

CAUTION! Sharp edges on metal parts. Always wear gloves.

10.1. Preparation

Before performing maintenance on an air heater that is already installed, do the following:

1. Set the thermostat to the lowest setting.
2. Close the manual gas valve.
3. Turn off the power supply to the air heater using the maintenance switch.

CAUTION! Always check for gas leaks after working on the air heater.

CAUTION! Do not use water when cleaning the air heater.

CAUTION! The heater must be electrically isolated during servicing.

10.2. Basic maintenance

To perform basic maintenance on the air heater, do the following:

CAUTION! When cleaning parts of the air heater, use a dry cloth, brush, compressed air or a vacuum cleaner. Never use a steel brush.

1. Inspect the outside of the heat exchanger.
2. Clean the fan guard on the outside of the heater. Clean the fan blades if required.
3. Open the access panel.
4. Clean the inside of the air heater. Focus on the following parts:
 - Body
 - Fan blades and motor
 - Heat exchanger
 - Temperature sensor
 - Vane switch (if present)
5. Check if the wiring, nuts and bolts are properly secured and tightened.

6. Grease any parts and bolts that are regularly loosened for maintenance.
7. Open the manual gas valve in the supply line and check if the supply lines are air tight, do not leak and do not contain air.
8. In order to guarantee the IPX4D classification, the screws of the cover of the housing and of the control box have to be fixed after connecting the wiring.

Some checks can only be performed when the heater is running. Do the following:

1. Reconnect the air heater to the power supply.
2. Switch on the air heater.
3. Check if the heater operates without problems. See §9. if any errors occur.
4. Check the air heater's combustion efficiency. If necessary:
 - Adjust the burner settings (see §8.1.).

10.3. Maintenance of the burner unit

The burner unit is an important part of the air heater and requires special maintenance.

The burner consists of the following parts (figure 18):

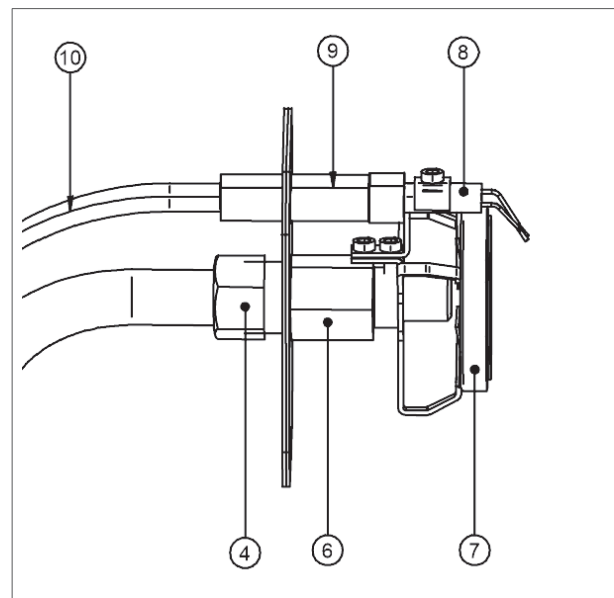

Figure 18 - Parts of the burner unit

4	Compression fitting (22 mm)	7	Flame stabilizer	9	Connection boot (x2)
6	Injector	8	Ignition electrode	10	Ignition cable (x2)

To perform maintenance on the burner unit, it must first be removed from the air heater:

1. Open the inspection hatch.
2. Remove the gas pipe by unscrewing the compression fitting (figure 18 - 4).
3. Remove the two connecting boots (figure 18 - 9) from the ignition electrode by gently pulling at the cables.
4. Unscrew the four nuts that connect the burner unit to the air inlet.
5. Remove the burner unit from the air heater.

To clean the burner unit, do the following:

1. Clean the various parts with a soft brush, a cloth or compressed air.
2. Pay extra attention to dirt building up on the stabilizer and the ignition electrode.

10.4. Extensive maintenance in poultry sheds

WARNING! Do not use a pressure washer to clean parts that contain electronics, such as the electric motor or the machine cover.

1. Use compressed air or a soft brush to clean the remaining parts from the air heater. Focus on the following parts:
 - a. The inside and outside of the body.
 - b. The fan blades and motor.
 - c. The temperature sensor.
 - d. The vane switch.
2. Remove all dust from the motor. Accumulated dust acts as insulation and can cause the motor to overheat.
3. Use a brush to remove any baked on dust.
4. Clean the burner unit (see §10.2.).
5. Open the gas valve.
6. Check if the gas supply line does not leak.
7. If the heater has been moved, check if the supply lines are connected properly.
8. Check if the wiring is secured properly.
9. Switch on the air heater and let it heat for a while. This burns off any remaining dust particles.
10. Stop the heating process.
11. Make sure the air heater is electrically isolated.
12. Disinfect the poultry shed and spread the bedding.

Instructions for cleaning the air heater with a high-pressure cleaner:

1. Never aim the high-pressure cleaner at components inside the air heater. When the water jet from the high-pressure cleaner hits components inside the air heater, parts can be damaged or bend.

2. Maintain a distance of 50 cm between the spray nozzle and the surface of the air heater being cleaned (figure 19).

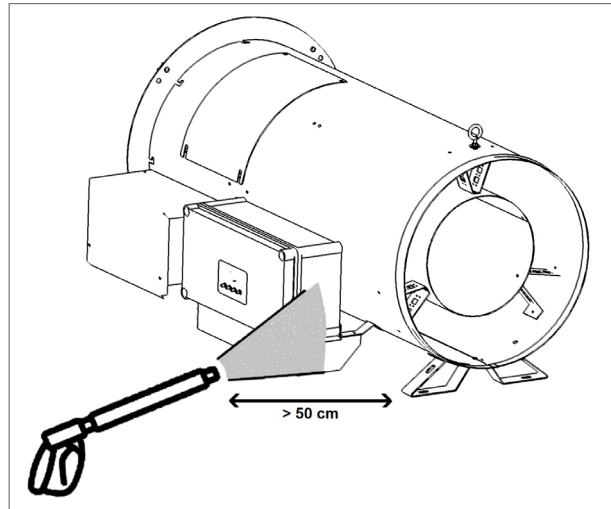

Figure 19 - Maintain a distance of 50 cm between the spray nozzle and the surface of the air heater being cleaned

3. Never spray on the electronics or the housing of the gas block (figure 20).

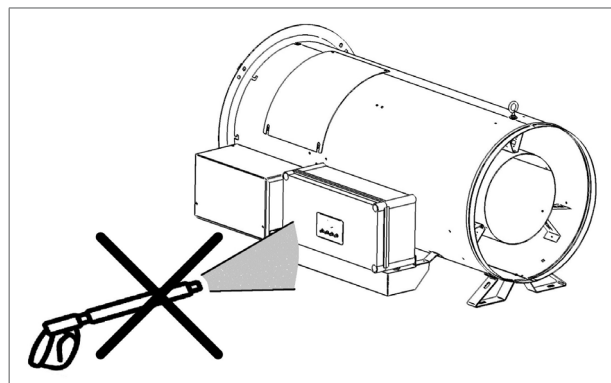

Figure 20 - Never spray on the electronics or the housing of the gas block

4. Never spray water or chemicals into the fan opening or fan motor (figure 21).

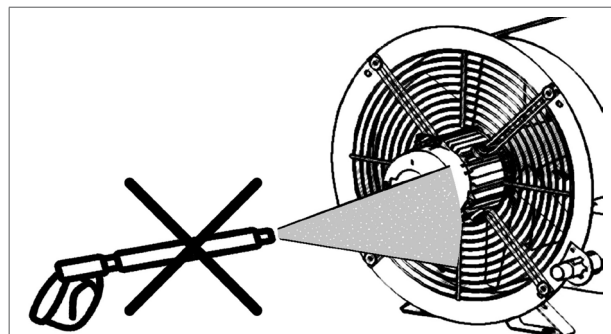

Figure 21 - Never spray water or chemicals into the fan opening or fan motor

5. Always rinse chemical cleaning agents off the air heater immediately with water. Chemical cleaning agents contain aggressive substances that can damage the stainless steel of the air heater.

11. Electrical wiring diagram

A complete electrical wiring diagram is shown in figure 22. The connections that are most important to the installation process are shown in figure 23.

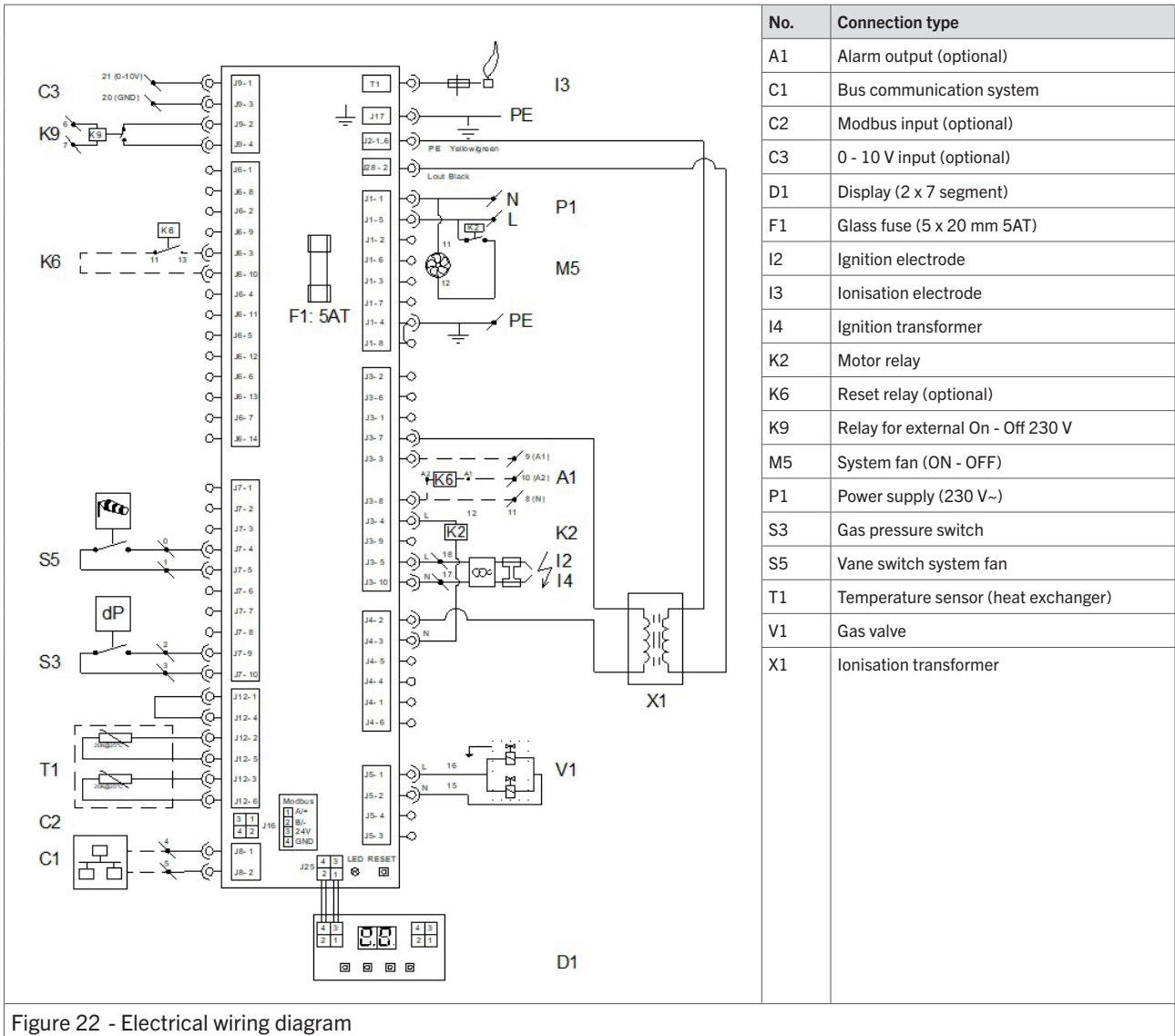

Figure 22 - Electrical wiring diagram

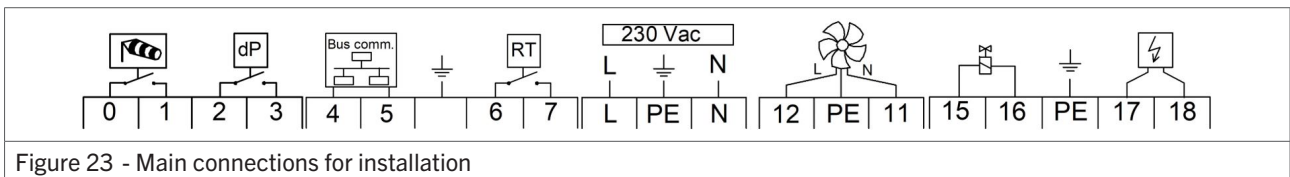

Figure 23 - Main connections for installation

12. Exploded view and spare parts

The parts of the air heater are shown in an exploded view in figure 24. The table below describes each part and shows the correct article number for a replacement part.

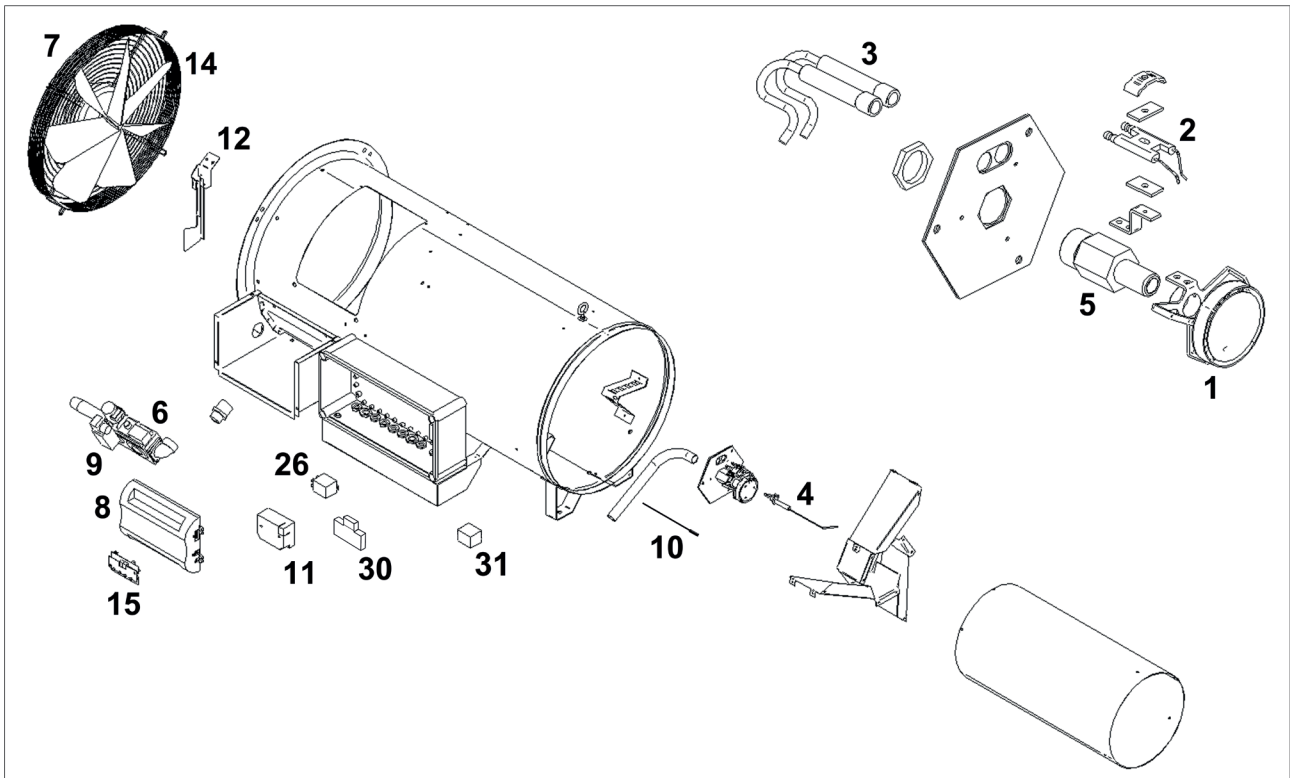



Figure 24 - Exploded view of the DHX

No.	Description	DHX40	DHX75	DHX100	DHX120
1	Flame stabilizer	GD3412	GD3412	GD3412	GD3412
2	Ignition electrode	GD200665	GD200665	GD200665	GD200665
3	Ignition cable	GD3400	GD3400	GD3400	GD3400
4	Ionisation electrode with cable	GD3393	GD3393	GD3393	GD3393
5a	Gas injector natural gas	GD3432	GD3433	GD3435	GD3437
5b	Gas injector propane	GD3422	GD3423	GD3425	GD3427
6	Gas valve	GD200713	GD200713	GD200713	GD200713
7	Fan motor	IP4213	IP4213	IP4227	IP4227
8	Burner control unit (EBM966)	GY5901	GY5901	GY5901	GY5901
9	Gas pressure switch	GD3930	GD3930	GD3930	GD3930
10	Temperature sensor (heat exchanger)	GY3933	GY3933	GY3933	GY3933
11	Ignition transformer	GD3404	GD3404	GD3404	GD3404
12	Vane switch	GD3405	GD3406	GD3410	GD3410
14	Fan blade	IP4215	IP4215	IP4228	IP4229
15	Display print	GY5902	GY5902	GY5902	GY5902
26	Motor relay	IK5200	IK5200	IK5200	IK5200
30	On/Off relay 230 V	IK5229	IK5229	IK5229	IK5229
31	Ionisation transformer	IK5102	IK5102	IK5102	IK5102

13. Disposal and recycling

	<p>The meaning of the symbol on the material, its accessory or packaging indicates that this product shall not be treated as household waste. Please, dispose of this equipment at your applicable collection point for the recycling of electrical and electronic equipments waste. In the European Union and Other European countries which there are separate collection systems for used electrical and electronic product. By ensuring the correct disposal of this product, you will help prevent potential hazards to the environment and to human health, which could otherwise be caused by unsuitable waste handling of this product. The recycling of materials will help conserve natural resources. Please do not therefore dispose of your old electrical and electronic equipment with your household waste.</p>
---	---

14. Declaration of conformity

Winterwarm Heating Solutions B.V.
Olden Goorweg 1
7108 AE, Winterswijk
The Netherlands

Declares that air heater types:

- DHX40, DHX75, DHX100 and DHX120
 - CE PIN: 0063BU3035

Are in accordance with the essential requirements of the relevant EU directives, being:

- 2016/426/EU (GAR) relating to appliances burning gaseous fuels
- 2014/35/EU (LVD) relating to the electric safety of appliances
- 2014/30/EU (EMC) relating to electromagnetic compatibility of appliances
- 2006/42/EG (MD) relating to the safety of machinery

Goods should be installed and used in accordance with our instructions and with the applicable local and international rules. Installation should be done by an authorized, qualified and competent installer.

Winterswijk, May 1st 2023

 <p>WINTERWARM HEATING SOLUTIONS B.V. Olden Goorweg 1 7108 AE Winterswijk Tel. 0543-546300</p>

Ir. M. Fiselier
Manager Research and Development

